



An Axis company

2N[®] LiftNet

Communicator for lifts



User Manual

Version: 1.9

www.2n.cz

The 2N TELEKOMUNIKACE a.s. is a Czech manufacturer and supplier of telecommunications equipment.



The product family developed by 2N TELEKOMUNIKACE a.s. includes GSM gateways, private branch exchanges (PBX), and door and lift communicators. 2N TELEKOMUNIKACE a.s. has been ranked among the Czech top companies for years and represented a symbol of stability and prosperity on the telecommunications market for almost two decades. At present, we export our products into over 120 countries worldwide and have exclusive distributors on all continents.



2N[®] is a registered trademark of 2N TELEKOMUNIKACE a.s. Any product and/or other names mentioned herein are registered trademarks and/or trademarks or brands protected by law.



2N TELEKOMUNIKACE a.s. administers the FAQ database to help you quickly find information and to answer your questions about 2N products and services. On www.faq.2n.cz you can find information regarding products adjustment and instructions for optimum use and procedures „What to do if...“.



2N TELEKOMUNIKACE a.s. hereby declares that the 2N[®] product complies with all basic requirements and other relevant provisions of the 1999/5/EC directive. For the full wording of the Declaration of Conformity see the CD-ROM (if enclosed) or our website at www.2n.cz.



The 2N TELEKOMUNIKACE a.s. is the holder of the ISO 9001:2009 certificate. All development, production and distribution processes of the company are managed by this standard and guarantee a high quality, technical level and professional aspect of all our products.

Content:

- 1. Product Overview
 - 1.1 Product Description
 - 1.2 System Components and Associated Products
 - 1.3 Changes
 - 1.4 Terms and Symbols Used
- 2. Description and Installation
 - 2.1 PSTN Central Unit
 - 2.2 Lift Cabin Audio Unit - Universal
 - 2.3 Lift Cabin Audio Unit - Compact
 - 2.4 Audio Unit - Machine Room
 - 2.5 Audio Unit - Lift Shaft - Cabin Roof
- 3. Configuration
 - 3.1 LN Programming
 - 3.2 Parameter Chart (FW v. 1.9.1)
- 4. Function and Use
 - 4.1 User Instructions
 - 4.2 Dispatching Centre Instructions
 - 4.3 Fireman Function
 - 4.4 Function Description (for Advanced Users)
- 5. Maintenance
 - 5.1 Battery Maintenance
 - 5.2 Firmware Upgrade
- 6. Technical Parameters
- 7. Supplementary Information
 - 7.1 Troubleshooting
 - 7.2 List of Abbreviations
 - 7.3 Regulations
 - 7.4 General Instructions and Cautions

1. Product Overview

In this section, we introduce the **2N[®] LiftNet** product, outline its application options and highlight the advantages following from its use.

Here is what you can find in this section:

- **1.1 Product Description**
- **1.2 System Components and Associated Products**
- **1.3 Changes**
- **1.4 Terms and Symbols Used**

1.1 Product Description

Basic Features

1. Up to 8-lift connectivity
2. Lift cabin, shaft and machine room audio units
3. Minimisation of interconnecting wiring
4. Excellent acoustic features
5. In-built back-up battery pack
6. Easy control and programming – voice menu
7. Checking call function
8. Lift blocking option during connection failure
9. Internal communication – triphony
10. Telephone/PC-based programming
11. USB port
12. User message recording option
13. Local dispatching option (Intercom)
14. Fireman function

Basic Description

2N[®] LiftNet (LN) is a communication system similar to the intercom. The audio units are connected (through a pair of conductors) to a common bus, to which one central unit (CU) is connected. The CU controls the system operation and provides connection to the dispatching office. Up to 32 audio units can be connected to the bus.

Each audio unit is uniquely identified: by lift number 1 to 8 and position: shaft bottom, cabin interior, cabin roof and machine room. The machine room audio unit can be shared by multiple lifts.

The CU is supplied with 12V DC. It contains an easily replaceable back-up accumulator battery pack (4 AA Ni-MH cells in a holder). The CU is responsible for battery charging and status monitoring. It indicates the charging status, telephone line status and current communication by means of three colour LEDs. It is also equipped with a USB port to provide comfortable parameter setting, voice message recording and software upgrade.

System Block Diagram

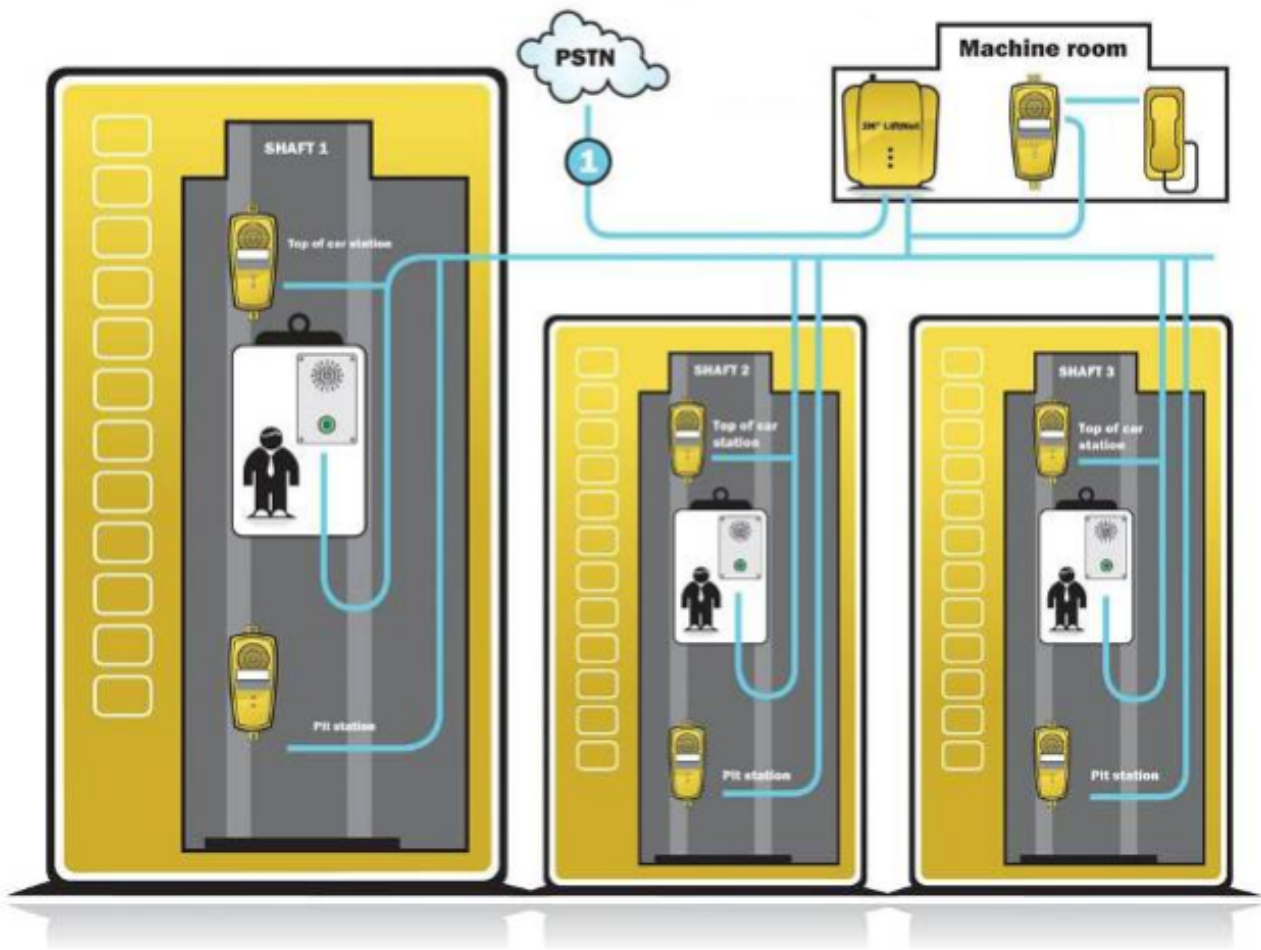

Figure: Example of Connection of PSTN CU and 3 2N[®] LiftNet Audio Units

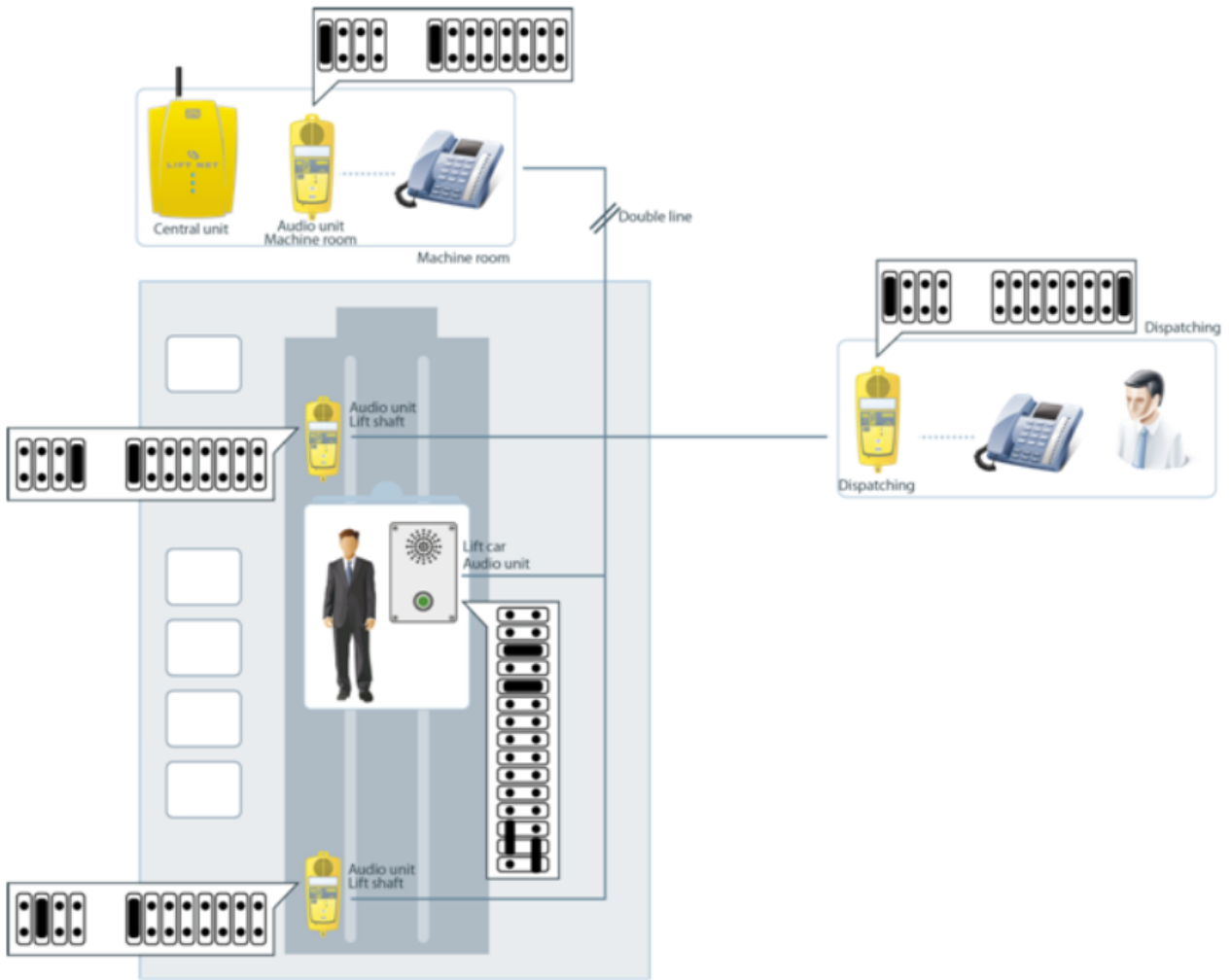

Figure: Example of CU and 2N[®] LiftNet Audio Units Local Dispatching Audio Unit Connection

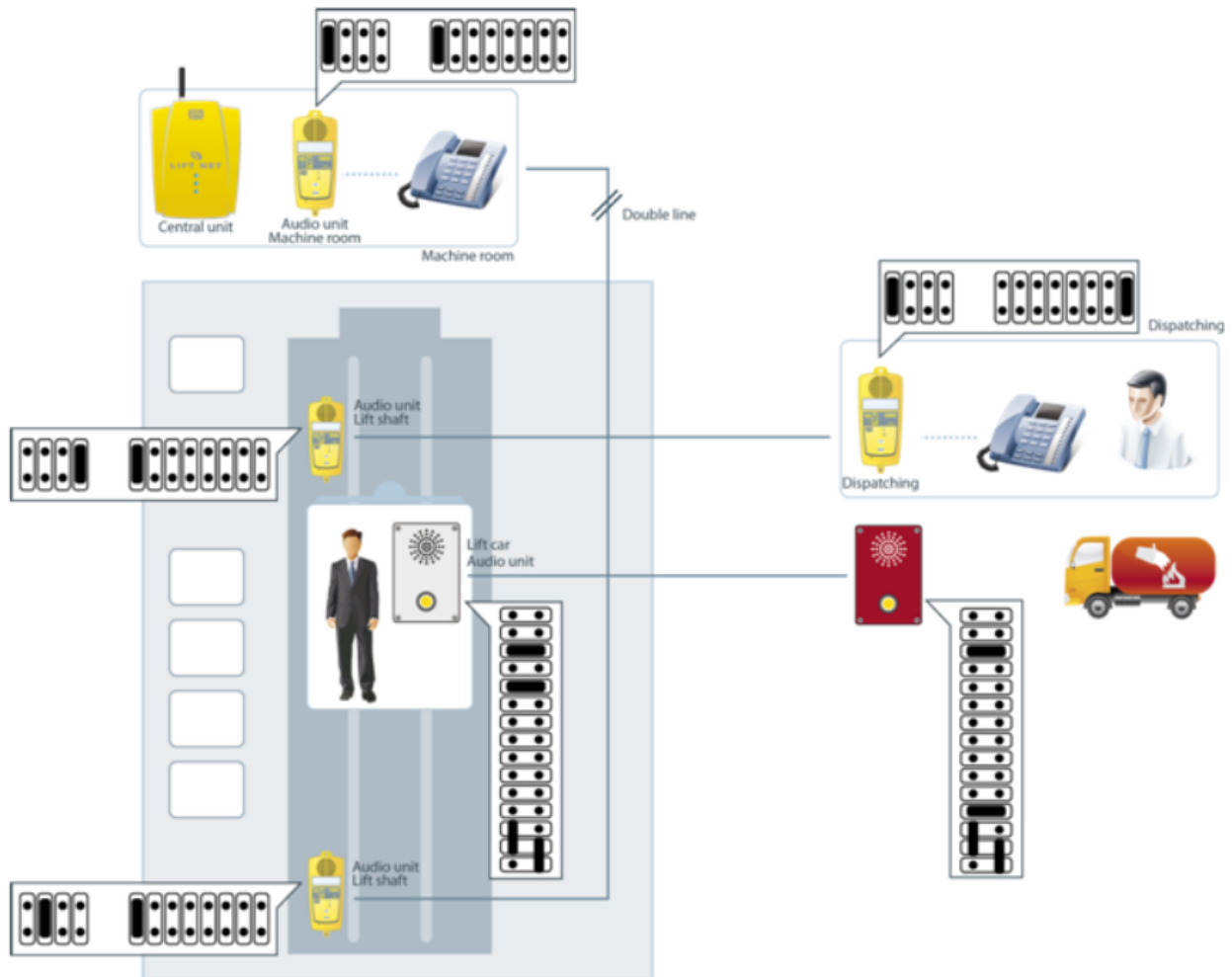

Figure: Example of Fireman Connection in 2N[®] LiftNet

1.2 System Components and Associated Products

System Components

Caution

- The 2N[®] LiftNet system components can be used within the LN system only.
- The audio units cannot be connected to a telephone line **without the CU!**

913600E - 2N[®] LiftNet PSTN Central Unit

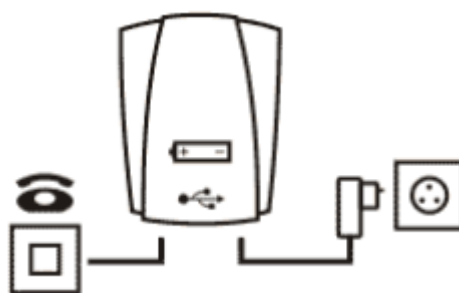

Enables to connect up to 8 lifts to an analogue PSTN or PBX line.

Including a power supply adapter and accumulator battery pack. A USB port for programming configuration.

913610E - 2N[®] LiftNet

Lift Cabin Audio Unit - Universal

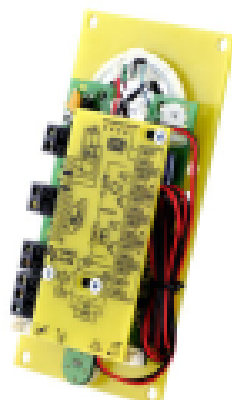

Audio unit electronics for lift cabins. Including loudspeaker and microphone (HandsFree).

Necessary terminals and door opening signal input (not optional).

913613E - 2N[®] LiftNet

Lift Cabin Audio Unit - Compact



A robust, metal-encased audio unit, provided with an ALARM button of the prescribed size, including indicators for blind people and backlit pictograms (hardened glass).

Easy wall surface mounting, 16-mm thickness only. Easy installation (paired wire connection).

913611ESET - 2N[®] LiftNet

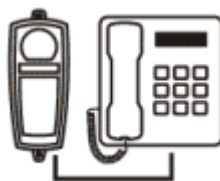

Audio unit – machine room/dispatching

Audio unit for machine rooms/dispatching, including siren and standard telephone set. Helps communicate with any audio unit in the system and program the CU without a PC. Equipped with a lift blocking contact in case LN fails to call for help. Can be programmed as a multiple-lift communicator. A robust yellow cover.

913612E – 2N[®] LiftNet

Audio unit – lift shaft



Audio unit to be installed in the lift shaft or upon the lift cabin roof.

A robust yellow cover. HandsFree mode, ALARM and TRIPHONY buttons, indication elements. Not intended for cabin use.

Associated Products

913630E – 2N[®] LiftManager

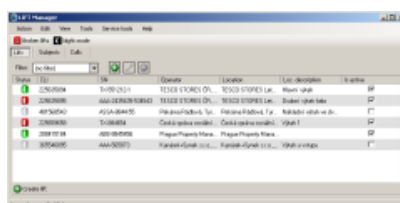

The **2N[®] LiftManager** system is intended for remote monitoring, control and communication with **2N[®] LiftNet**, **2N[®] EasyTalk** and **2N[®] SingleTalk** units. Part of the **2N[®] LiftManager** installation is Service Tool application which is aimed to manage configurations of available devices (**2N[®] LiftNet** units). **2N[®] LiftManager** is intended for use by companies (or individuals) who install or maintain lifts.

501300E - 2N[®] EasyGate

GSM Solution for **2N[®] LiftNet** and **2N[®] SingleTalk**



PSTN line replacement.

Simple installation without programming.

501399E - 2N[®] EnergyBank

Backup power supply for GSM gateway



Back-up power source in case of power supply failure.

Simple installation.

1.3 Changes

You can see on the table below upgrade an innovations.

Manual version	Upgrade an innovations
1.8.0	In firmware 1.8.0 <ul style="list-style-type: none"> • New Fireman function (fire call setup from the Fire Station to the cabin in the shaft with the lowest address)
1.7.0	In firmware 1.7.0 <ul style="list-style-type: none"> • New Alarm - intercom function (alarm call setup to the machine room audio unit) • This new function can also be used for setup of a checking call to the machine room audio unit
1.6.0	In firmware 1.6.0 <ul style="list-style-type: none"> • Added parameter 932 (cabin audio unit loudspeaker volume control for alarm and incoming calls)
1.5.8	In firmware 1.5.8 <ul style="list-style-type: none"> • Added Italian voice menu • Support of new audio units - 913613E and 913613WBE
1.5.5	In firmware 1.5.5 <ul style="list-style-type: none"> • Added parameter 990 (System settings) • Automatic restart of audio units for CU - audio unit communication monitoring (WatchDog)
1.5.2	In the manual <ul style="list-style-type: none"> • Modified description in Subs. 2.5 Audio Unit - Machine Room In firmware 1.5.2 <ul style="list-style-type: none"> • New voice menu

- Added system messages (page 59)
- Shorter timeout for the first "Wait please" message after emergency call activation
- Added parameters 978, 979
- New default value for parameter 914 (delayed call set to 0 seconds, CANCEL still active)

Manual Symbols

The following symbols and pictograms are used in the manual:

Safety

- Always abide by this information to prevent persons from injury.

Warning

- Always abide by this information to prevent damage to the device.

Caution

- Important information for system functionality.

Tip

- Useful information for quick and efficient functionality.

Note

- Routines or advice for efficient use of the device.

2. Description and Installation

The section is divided according to system components into the following subsections:

- 2.1 PSTN Central Unit
- 2.2 Lift Cabin Audio Unit - Universal
- 2.3 Lift Cabin Audio Unit - Compact
- 2.4 Audio Unit - Machine Room
- 2.5 Audio Unit - Lift Shaft - Cabin Roof

Each subsection includes:

- Component Description
- Before You Start
- Mounting
- Electric Installation

2.1 PSTN Central Unit

Description

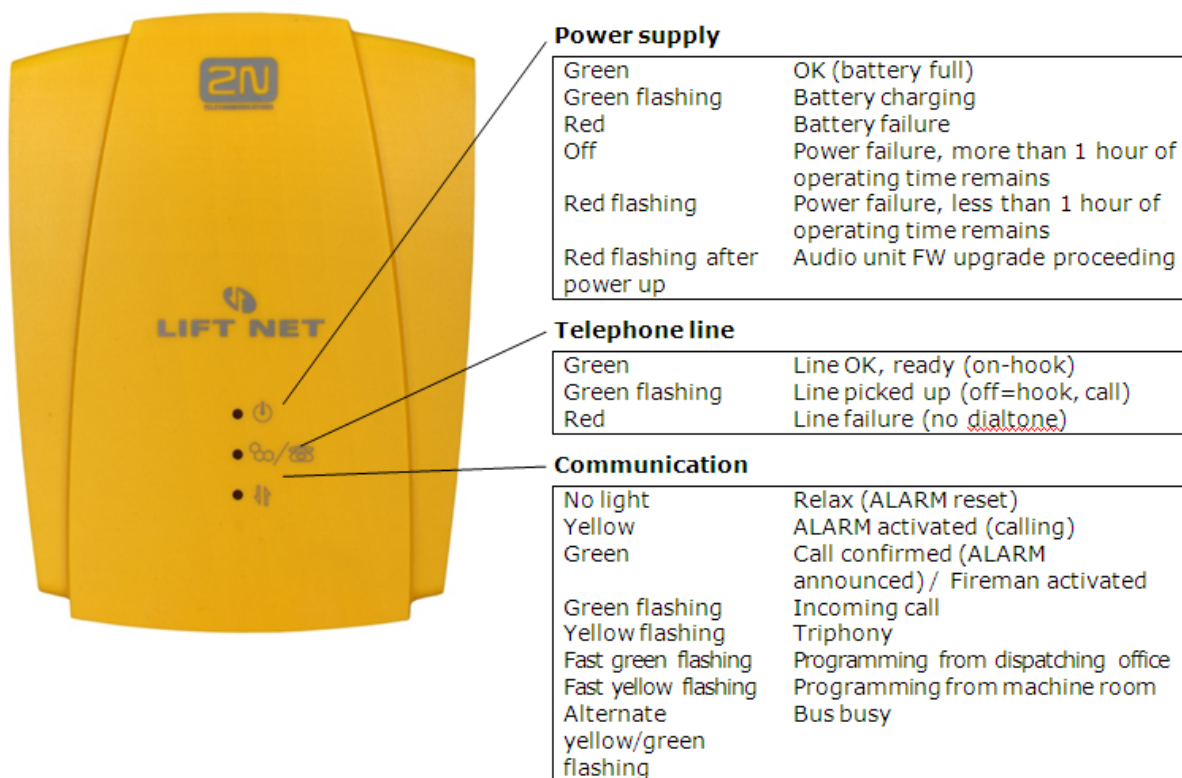

Figure: Central Unit LED Indicators

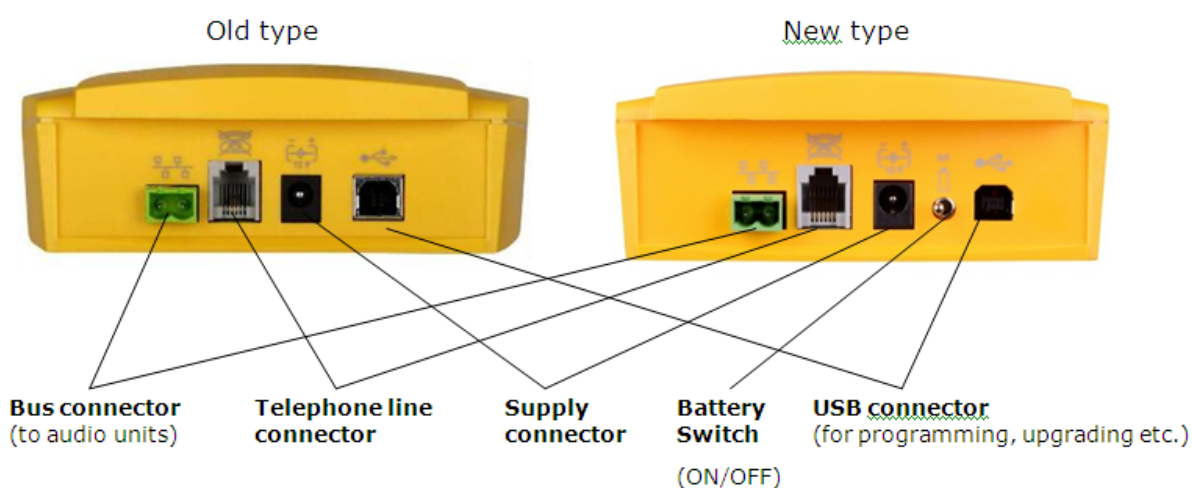

Figure: Central Unit Connectors

Warning

- Do not open the CU during the warranty period.
- Later, open for battery replacement only.

Before You Start

CU installation conditions

- The CU is not designed for outdoor applications.
- Do not mount the CU onto vibration-producing machines.
- Install the CU vertically to allow air flow for cooling purposes (never cover the CU with any cloth or install it in another closed box).
- You may install the CU into the lift switching board unless the temperature exceeds the acceptable limit.
- The CU may be operated in the lying position on a desk at the room temperature of up to 25 °C.

Product Completeness Check

Check the product for completeness before installation please:

- 1 central unit
- 1 terminal - inserted on the bus connector
- 1 accumulator battery isolation tape is present (sticking out of the cover)
- 1 power supply adapter conforming 12V DC to the local power network requirements
- 1 telephone cable with RJ terminals
- 2 wall dowels
- 2 dowel screws
- 1 manual, either in the printed or CD format
- warranty certificate

Checking of Accumulators

Instructions

1. Completely pull out the tape that sticks out of one opening on the back side of the CU. This tape protects the inserted accumulators against discharging during storage. With this tape it is possible to store the product (if supplied including

batteries) ½ year since the shipping date, which is indicated on the packaging. After this period the claims, if any, regarding the battery warranty cannot be accepted.

2. Do not connect anything to the CU and if any control lamps light up after the tape has been removed wait a few seconds until they turn off. (With new HW type, you have to switch the battery button into the position ON.).
3. Now watch the "power" control lamp on the CU carefully for a few seconds (not in direct sunlight because the flashing is not strong):
 - a. **Weak and short green flashing** – The battery is OK and fully charged, you may continue with the installation. If the product was stored for longer period than ½ year, or under temperature exceeding 25 °C proceed according to paragraph b.



Caution

- The product needs to be put in operation **after the tape has been removed.**

It can be stored no longer than one week without charging; after having been fully charged no more than 1 month.

- b. **Weak and short red flashing** – Some battery cells are discharged. In such case connect the 12V DC power adapter (do not connect any audio units!) and let the CU charge for at least 24 hours, even after the indicator has starting showing that the battery is charged. This is a so-called compensatory cycle, which balances out the condition of the individual cells after a long period of storage.
 - c. **No flashing** – The battery is fully depleted and may be damaged. Replace the battery with a new recommended type (SANYO Eneloop 2000).
4. You may now install the CU.

CU Mounting

It is recommended to install the CU in a room that is secured against unauthorised persons, such as the lift machine room, switching station etc. On an easily accessible place there is a risk of telephone line misuse or SIM card misappropriation (in the GSM version).

Mount the CU onto a wall using the attached dowels and screws.

CU Connection

Supply

Use the included adapter or a 12V DC power supply with appropriate parameters (stabilised).

Warning

- Never use an AC or non-stabilised DC power supply to avoid CU damage

Bus Connection

Requirements

- With multi-wire cables, always use a symmetrical twisted pair of conductors (i.e. those that match each other). Standard UTP cables contain twisted pairs.
- With special cabling (in the cabin), use the adjoining cables and make sure that the nearest neighbouring conductors do not radiate interference (power cables, video signals, etc.).

Recommendations

- Do not lead the bus close to power cables, especially in long-distance sections.
- Branch the bus to shorten the total length of sections.

Safety

- The bus is electrically isolated from the telephone line circuits according to the EN60950 standard requirements and its low voltage cannot cause any electrical accident.

CU Connection to Telephone Line

LN works in a wide range regardless of polarity and line parameters (refer to Technical parameters). Connect it using the attached cable with an RJ-12 terminal.

Caution

- One CU may be connected to one telephone line only and no other telephone terminal equipment may be connected to this line.
- 2N[®] LiftNet requires the telephone line exclusively for itself. This means that NOT even a system through which the telephone line goes (priority connection, ESS, e.g.) may be connected to this telephone line.
- No double or group serial lines may be used.
- No telephone "multiplugs", even the "intelligent" ones, may be used.
- Never connect LN to an ISDN line.

CU telephone network connection options

There are four connection options:

- PSTN line
- PBX line
- GSM gateway
- VoIP adapter

Direct PSTN Connection

This is the simplest and most reliable type of connection. High operational costs (flat rate costs) are a drawback of this solution.

Telephone line requirements

- No double or group serial line.
- The telephone socket including cabling is a property of the telecom company and may not be tampered with.

Other recommendations

- Notify the telephone network provider of your LN installation and submit certification upon request.
- Your follow-up cabling has to meet all applicable safety regulations.

- You are recommended to secure your cabling physically against piracy (with a telephone lock, e.g.).

PBX Connection

This is the least-cost solution where a PBX and an unused PBX line are available.

PBX line requirements

- The PBX to be used must work reliably even in the case of power outage. Large PBXs are mostly equipped with a back-up power supply, smaller PBXs usually use PSTN line redirection in the event of power failure. Consult the problem with the technician responsible for your PBX. An error during power outage may result in LN calling an undesired station.
- Relevant call access rights have to be assigned to the PBX line to be used (use a standard telephone set to check whether the line can make calls to all required „external“/CO line numbers).
- While programming, enter all necessary PSTN prefixes (typically a zero), or (which is a better solution) make the PBX not require a prefix (so-called automatic CO line seizure).
- To make dispatching office-lift calls, you have to know the extension number and how to get through to it (dial-in, DISA, operator).
- The dispatching office-lift connection may not depend on the operator's presence, no call redirection to a fax machine in the night mode is allowed, etc.

Other recommendations

- Make an agreement with the PBX owner regarding operating costs (LN outgoing calls are billed at the owner's expense with the exception of free calls on "green lines").

Tip

- Where a non-stop security or porter's service is available, the personnel can be trained in rescue operations and LN can be programmed to call this service.

GSM Gateway Connection (Temporary - Substitutes the GSM CU Version, Part No. 501303E)

Used wherever no fixed telephone line is available.

Requirements

- The GSM gateway has to be functional even in the case of power outage.

- The GSM gateway has to recover its function without requiring the PIN.

Other requirements

- Find a suitable place or use a special (directional) antenna where the GSM signal quality is poor.
- Secure the GSM gateway SIM card against misappropriation.
- With a pre-paid SIM card, monitor the credit use and on-time replenishing.

VoIP Adapter Connection

This is the cheapest solution where a reliable Internet connection is available.

Requirements

- The entire system has to be functional even in the case of power outage.

Other recommendations

- As the VoIP technology is rather complicated, make sure that the dispatching office personnel monitor connectivity reliably (evaluate the checking calls).

Tip

- Some VoIP adapters have two independent telephone lines. A majority of subscribers use just one line and the other line is thus available "free of charge".

Operation without Telephone Line

LN can be used as an intercom during lift assembly work even without a telephone line. In that case, make sure that the lift blocking function is not activated until the telephone line has been connected.

USB Port Connection

Recommendations

Do not leave a PC connected for a long time unless necessary in order to minimise risk of PC damage due to HV shock from the telephone line during storms, e.g.

Interruption of Operation, Battery Maintenance

Caution

- **Never** leave the batteries discharged for unnecessarily long periods.
- If the battery is fully discharged please recharge it as soon as possible.

For a detailed description of situations that require your attention due to the state of accumulators during interruption refer to the Maintenance section. **Remember that the state of accumulators is essential for system operation in any case.** The Maintenance section also contains instructions for accumulator maintenance, including replacement.

2.2 Lift Cabin Audio Unit - Universal

Description

The user is not in a direct contact with this product.

The controls and indicators depend on the lift cabin control panel type. The indicators (e.g. bulbs or LEDs) are working in accordance with the applicable standards.

Address Setting – see the Installation section for details.

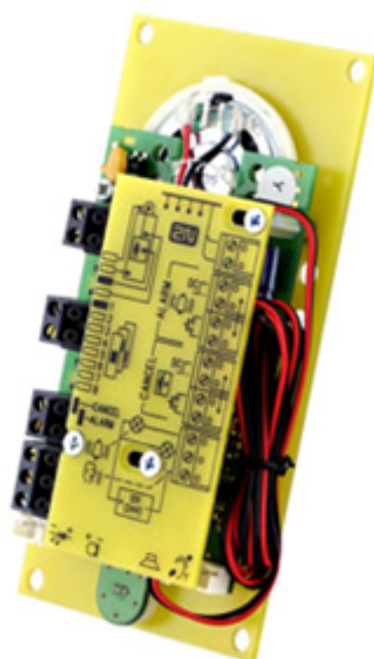

Figure: Lift Cabin Audio Unit – Universal

Before You Start

Requirements

- The panel has to be installation-ready, including loudspeaker perforation.
- The panel has to be equipped with the following obligatory elements:
 - ALARM button;
 - Backlit symbol "Request accepted";
 - Backlit symbol "Connection established".
- The above mentioned elements have been located as required by applicable regulations.
- There must be free space of at least 65×130×20 mm behind the panel.

Product Completeness Check

Check the product for completeness before installation please:

- 1 board with electronics
- 4 terminals slid on the board pins, see the photo
- 4 jumpers slid on the board pins, see the cover print
- 1 mounting panel
- 1 directly/cable-connected loudspeaker
- 1 directly/cable-connected microphone
- 1 printed cover
- 5 tightening strips

Mounting

Main Board Mounting

This audio unit is mounted behind the lift control panel. Typically, the panel is ready for installation as shown in the drawing below:

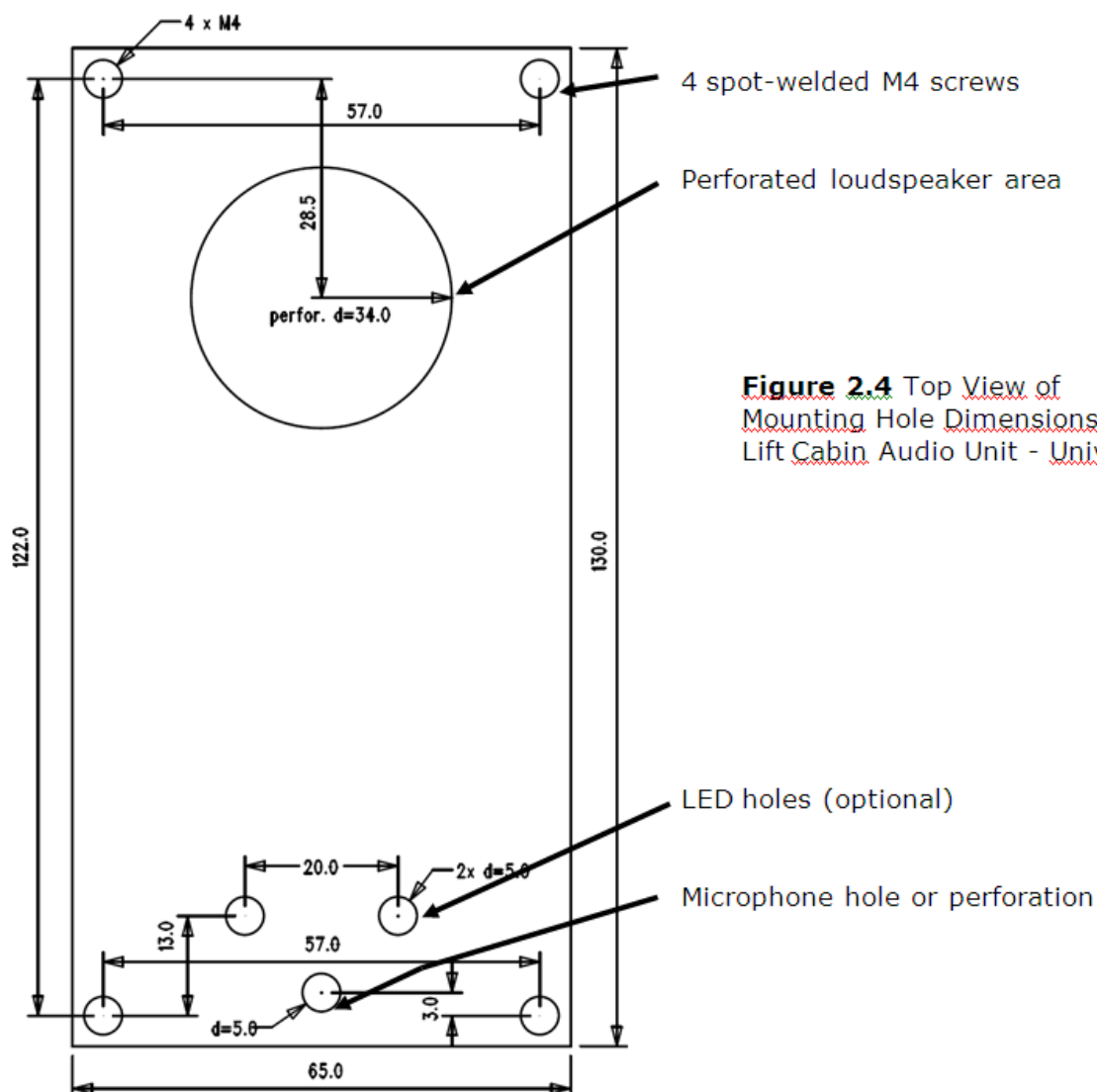

Figure 2.4 Top View of Mounting Hole Dimensions for Lift Cabin Audio Unit - Universal

To mount the audio unit, you need 4 electrically spot welded M3 or M4 screws, a sufficiently large loudspeaker perforation area and a microphone hole on the inner (back) side of the panel. If needed, you can fix the audio unit on a perfectly degreased surface with a good-quality two-sided foam self-adhesive tape.

Warning

- **Leave no gap** between the lift control panel and the audio unit surface to avoid acoustic loudspeaker fault and acoustic loudspeaker-microphone feedback.
- **Do not use** this type of audio unit in a position other than mounted on a sufficiently large board. The acoustic properties of an uninstalled audio unit cannot be guaranteed.

Separate Microphone Mounting

If the microphone is separated (connected by cable) it has a 25×25 mm large board with self-adhesive foil. This helps you mount it easily behind any hole in the panel (the minimum hole diameter is 5 mm, or a group of smaller holes of the same total area). Just glue the microphone directly onto the required place from behind (be sure to degrease and clean the surface carefully before!).

Requirements

- The minimum distance between the loudspeaker and microphone centres is 90 mm. A lower distance may lead to acoustic feedback. A greater distance (within the available 1m cable) does not matter.
- Make sure that the glued-on microphone does not pick up (even partially!) the acoustic pressure from the space behind the panel. Such sensing might result in acoustic feedback since the loudspeaker strongly radiates sound into the cavity.

Separate Loudspeaker Mounting

The loudspeaker is equipped with a cable and can be separated from the electronics by simply sliding it out within the reach of the cables delivered (1m). This option is useful where there is not enough space for the whole electronic equipment. Fit the loudspeaker according to the instructions below:

- While gluing choose such procedures or adhesives that prevent membrane damage by adhesives and volatile substances, or heat.
- We recommend you to keep the loudspeaker sealed to eliminate vibrations.

Frequently Asked Questions Concerning Loudspeaker

- *Is it possible to use a common loudspeaker for the communicator and floor announcing machine?*
 - No, it is not.
- *May I use a loudspeaker of my own?*
 - Yes, but make sure that the impedance is 64 Ω. By doing this you assume responsibility for sufficient volume and frequency range.
- *May I place the loudspeaker on the cabin ceiling?*
 - This placement is not recommended.
- *May I use a longer cable with the loudspeaker?*
 - Yes, but not with the microphone.

Electric Installation

Description of Terminals, Connectors and Jumpers

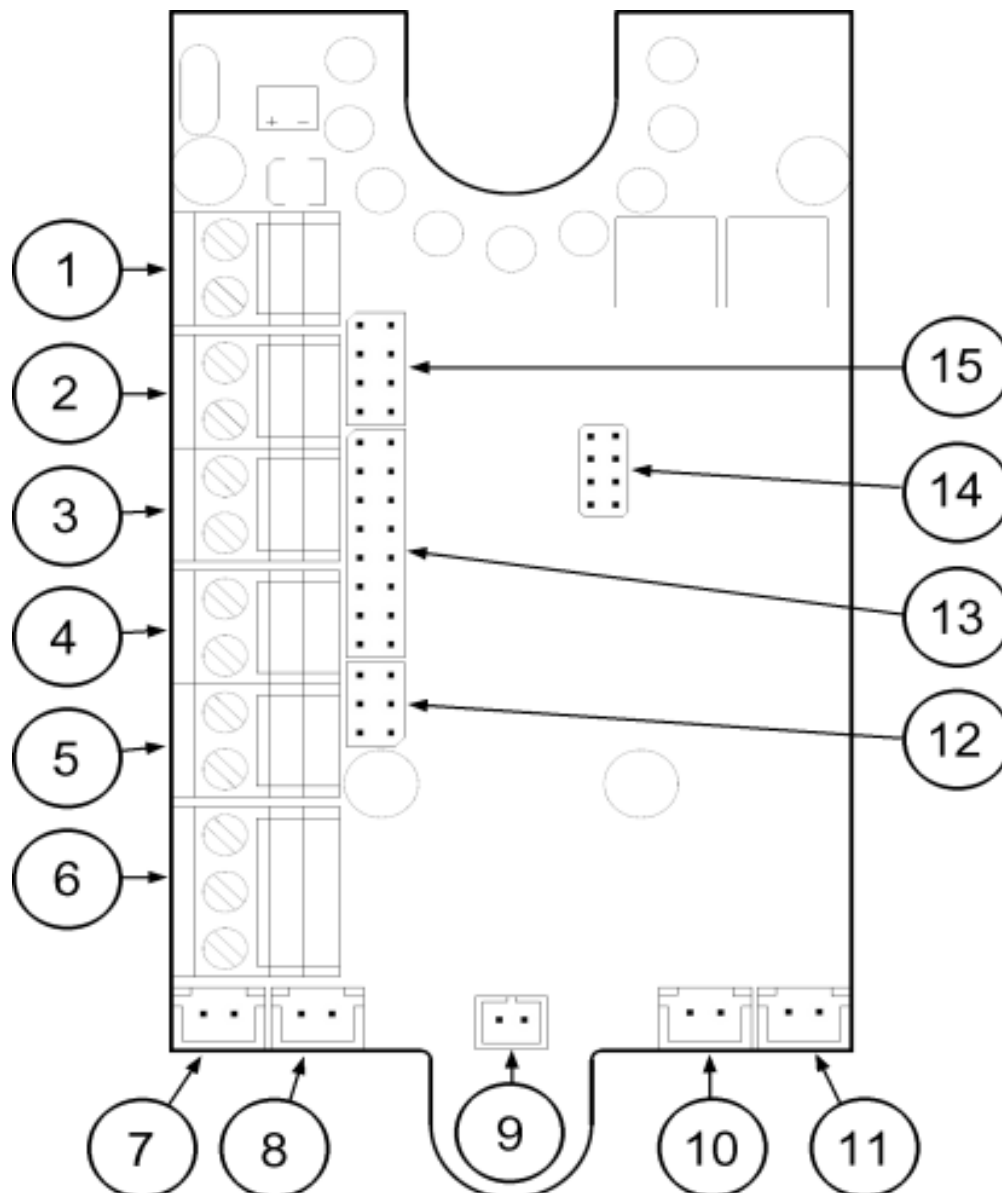

Figure: Description of Terminals, Connectors and Jumpers for Lift Cabin Audio Unit - Universal

Terminals		Connectors	
1	Bus	7	"Request accepted" LED
2	ALARM, voltage activation	8	"Connection established" LED

3	ALARM, contact activation	9	Microphone connector
4	CANCEL, voltage activation	10	Loudspeaker connector
5	CANCEL, contact activation	11	Induction loop connector
6	indicator switches	14	Service connector
Configuration jumpers		LED indicators (rear side):	
12	ALARM / CANCEL inversion	1. (yellow)	Request accepted
13	Lift number	2. (green)	Connection confirmed
15	Audio unit position	3. (yellow)	Triphony
		4. (red)	Upgrade or error

Note

- If external LEDs are connected to connectors 7 and 8, on-board LEDs 1 and 2 will not be shining.

Address Setting

The audio unit address means setting of two jumpers, namely the lift number (1 to 8) and audio unit position (refer to the cover drawing). If you install the audio unit in the cabin of lift 1, you need not change the jumper configuration. In other cases, follow the instructions below:

Instructions

1. Release slightly the three screws on the electronics cover.
2. Slide the cover to the right to expose the jumpers.
3. Set the required changes as shown on the electronics cover.
4. Replace the cover and tighten the screws.

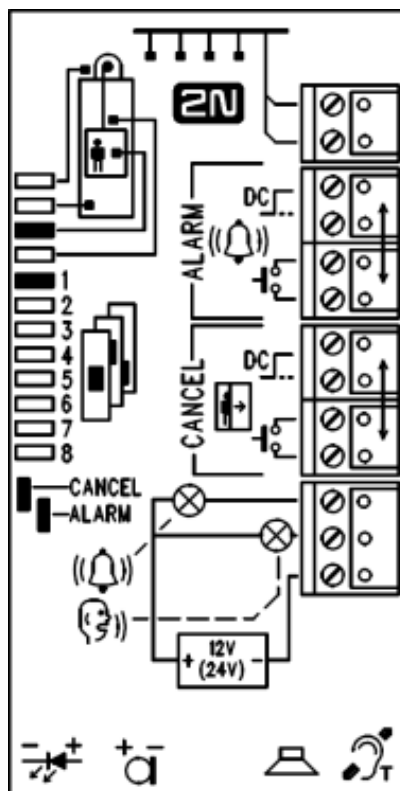

Figure: Address Setting for Lift Cabin Audio Unit - Universal

i Notes

- Make sure that two audio units do not have an identical address to avoid system error.
- The position-setting jumpers are employed exceptionally, e.g. where a certain audio unit type is used in a position other than normal.
- To recover the initial address setting, follow the drawing on the cover.

Bus Connection

The connection polarity is arbitrary.

! Warning

- Connection to different, e.g. higher-voltage, cables leads to damage or destruction of the audio unit.

Caution

- The unit is powered via a 2-wire bus from the central unit. Unplugging of the bus from the CU causes switching off of the unit.
- Avoid the audio unit address duplicity.

ALARM Button Connection

Requirements

The ALARM button design (colour, symbol, button surface, mechanical run) and location have to meet the requirements of the particular installation.

Button control

Requirements

- The ALARM button has to be equipped with a normally open (NO) or normally closed (NC) contact that is not connected with any other circuit.
- None of the ALARM button terminals may be connected electrically with any other electrical circuit and a voltage source other than the NO/NC contact.
- If one of the ALARM contacts is connected to another circuit, appropriate isolation strength according to applicable standards has to be ensured between the contacts.

Instructions

1. Leave the ALARM terminal in the LOW position (3).
2. With a normally closed contact, leave jumper (12) – right in the default position.
3. With a normally open contact, switch jumper (12) – right into the HIGH position.

Voltage control

Requirements

- DC 12 to 48V voltage
- The voltage signal has to be active even in the case of power failure.

Instructions

1. Switch the ALARM terminal by two pins up into position (2).
2. For activation by voltage connection, leave jumper (12) - right in the default position.
3. For activation by voltage disconnection, switch jumper (12) - right into the HIGH position.

Caution

- Jumper setting, as printed on the unit cover of pre-production samples, is only valid for CANCEL and wrong for ALARM.
- See above for the proper setting.

Warning

- Ignoring the instructions above may lead to product damage.

CANCEL Input Connection (Door Contact, Optional)

This input helps cancel a rescue request if the lift is fully functional. When the ALARM button is pressed, the system waits for a pre-programmed period of time, which is a little longer than the maximum lift running time. If the lift is functional, it arrives in the required station within this timeout and opens the door. In that case, the rescue request is cancelled. If the door fails to open, the request is accepted.

Find out before installation whether the door opening signal is available in the lift cabin.

Requirements

- In double-door lifts, the signal has to be active only if both the doors open successfully and let the people out.
- The door position signal has to work even in the case of power outage.

Contact control

Requirements

- None of the CANCEL terminals may be connected electrically with any other electrical circuit and a voltage source other than the contact.

Instructions

1. Keep the CANCEL terminal in the LOW position (5).
2. With a normally open contact, leave jumper (12) - left in the default position.
3. With a normally closed contact, switch jumper (12) - left into the LOW position.

Voltage control

Requirements

DC 12 to 48V voltage

Instructions

1. Switch the CANCEL terminal by two pins up into position (4).
2. For activation by voltage connection, leave jumper (12) - left in the default position.
3. For activation by voltage disconnection, switch jumper (12) - left into the LOW position.

Warning

- Ignoring the instructions above may lead to product damage.

Note

- Remember to program delayed calling to make the CANCEL connection work successfully.

Indicator Connection

The basic configuration providing (using an external source) a sufficient illumination intensity of indication elements is shown in the figure:

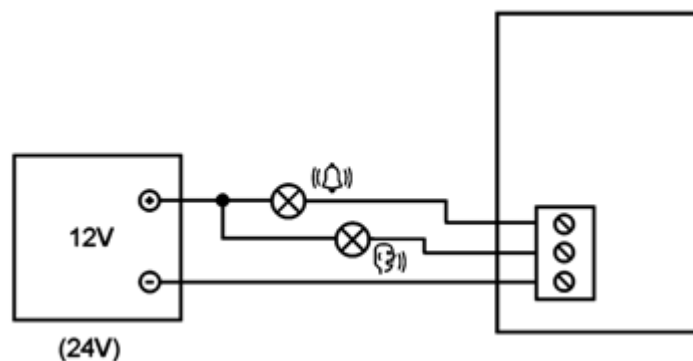

Figure: Basic Indicator Connection for Lift Cabin Audio Unit – Universal

Requirements

- The DC power supply has to be backed-up.

Notes

- LN continues working except for the indicators during power outage.
- The indication elements (bulbs, e.g.) may have the maximum current of 200 mA each.
- Mind polarity in this case.

Alternative indicator connection (LED)

Today's LED producing technologies help achieve a relatively good illumination intensity at a low current supply. If a 5 mA LED (with diode loss of approx. 2V) is able to provide efficient illumination in the lift, no power supply is needed. For this configuration see the figure below:

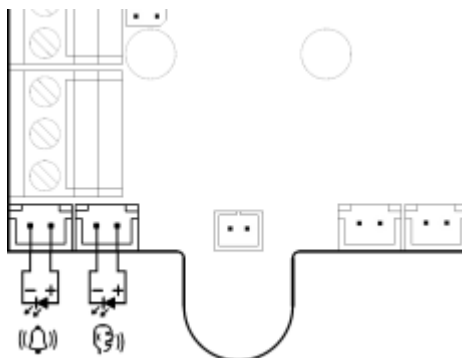

Figure: Alternative Indicator Connection for Lift Cabin Audio Unit – Universal

i Notes

- The cables required for this configuration are not part of the standard delivery but are available upon agreement.
- In this configuration, the auxiliary indicators on the PCB are not shining.

Induction Loop Connection

The regulations that apply to communicator installations may require a mandatory loop for persons with defective hearing in the lift cabin. In that case, connect the loop to connector (10) with any polarity. The loop including a 1m long cable can be part of your delivery if agreed.

Requirements

- The induction loop has to be placed behind a non-metal, non-magnetic cover in the control panel because the magnetic field of the induction loop cannot go through the metal control panel.
- The induction loop has to be labelled with an appropriate symbol (ear) placed according to applicable standards.

2.3 Lift Cabin Audio Unit - Compact

Description

This audio unit is designed for lift wall mounting. No opening has to be cut for installation since the audio unit is surface mounted.

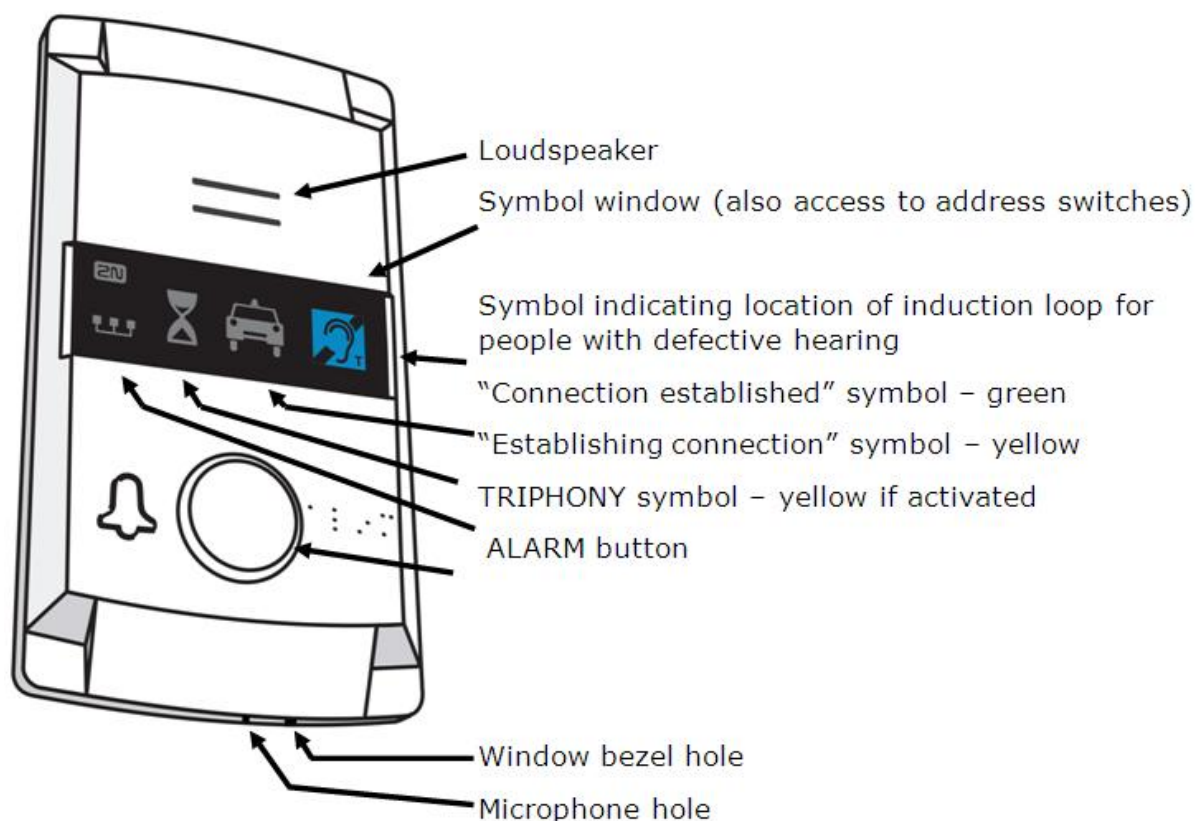

Figure: Description of Lift cabin Audio Unit - Compact

Operating instructions

1. Activate by pressing the ALARM button. The "Wait" symbol lights up and, once communication has been established, the "Connection established" symbol comes on.
2. To activate the TRIPHONY mode press the button on the shaft or machine room audio unit for which the same address has been set.

Before You Start

Requirements

- The lift wall surface must be perfectly flat.
- The mounting place must comply with applicable regulations (e.g. standard ALARM button elevation and relative distance from other lift buttons).

Product Completeness Check

Check the product for completeness before installation please:

- 1 Compact audio unit
 - 1 window with printing
 - 2 terminals inserted in the back side connector
- 1 long hexagonal 2mm round-head wrench
- 4 M4×8 screws
- 4 headless M4×30 screws
- 4 M4 nuts
- 4 fan washers

Address Setting

The audio unit is set as lift cabin 1 by default. If you want to change the address, you are recommended to do so before mounting.

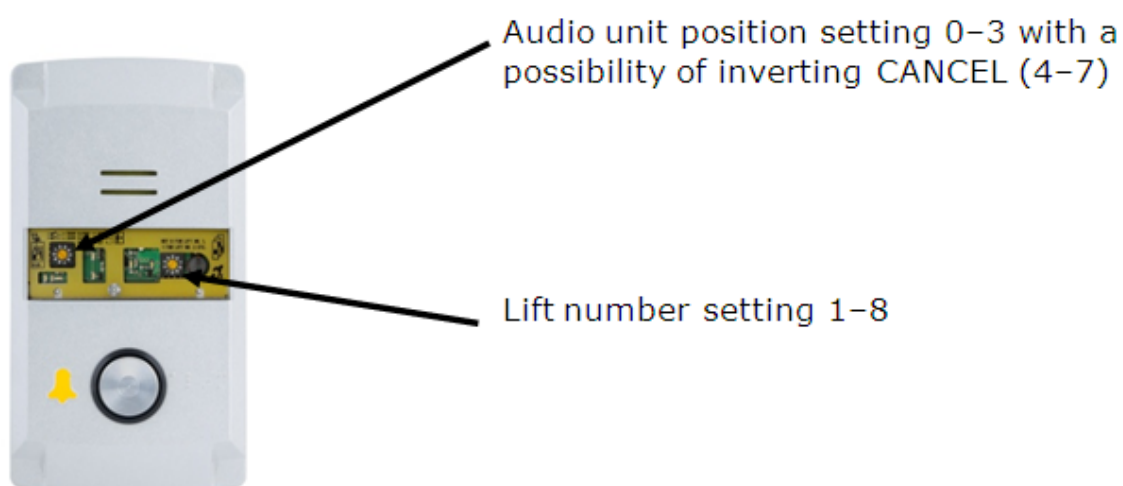

Instructions

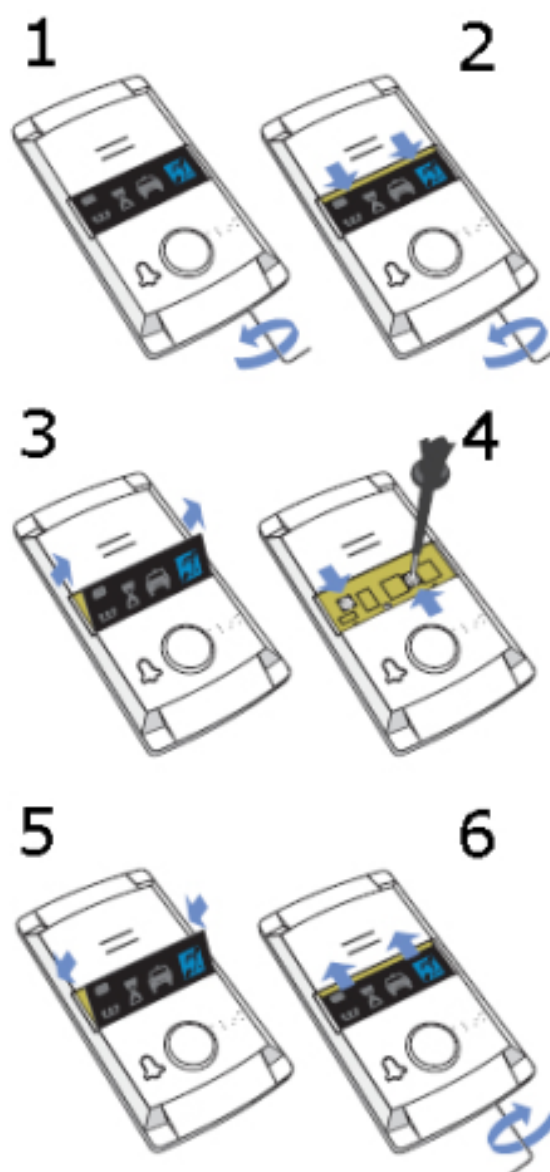

Figure: Address Setting for Lift Cabin Audio Unit - Compact

1. Insert the hex wrench (included in the delivery) in the bottom unit edge hole; turn left about 10 times until it puts up resistance.
2. The window slides down by itself or with little assistance, showing its upper brim.
3. Tilt the window forwards and remove.
4. Set the audio unit address using a screw driver:

left rotary switch: 0 or 4 ... machine room 1 or 5 ... shaft bottom 2 or 6 ... lift cabin 3 or 7 ... lift cabin ceiling	right rotary switch: 1-8 = lift number
--	--

 **Caution**

- **Right rotary switch:** 1 to 8 print, i.e. set 1 for lift number 2 etc.

 **Note**

- **Left rotary switch:** If you use the CANCEL input and the contact is **open** with the door closed, set the left switch into one of positions 0 to 3; if the contact is **closed** with the door closed, set the left switch into one of positions 4 to 7.

1. Replace the window.
2. Insert the hex wrench (included in the delivery) in the bottom unit edge hole, turn right about 10 times until the window slides under the panel edge and tighten applying light force.

Mounting

Just drill holes into the lift cabin wall as indicated in the drawing below or as printed 1:1 on the audio unit package. The larger hole is intended for cable passage. Round the hole edges to avoid cable damage!

Electric Installation (Earlier HW)

⚠ Caution

- Be sure to connect the wires before wall mounting. The connectors are separable - remove them, connect the wires, tighten the screws and replace the connectors.

Connectors

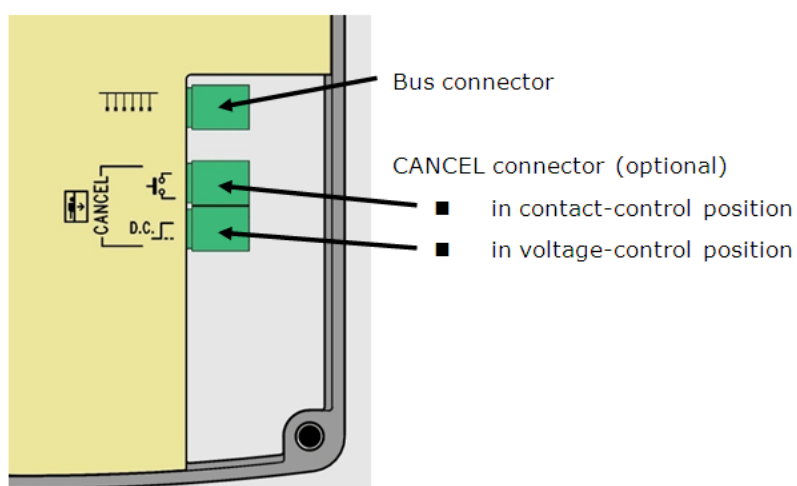

Figure: Connectors of Lift Cabin Audio Unit - Compact

Electric Installation (Later HW)

Terminals

Telephone line / LN bus		Refer to ST or LN User Manual	
ALARM terminals	DC = voltage control *)	5 - 24Vdc, any polarity	Emergency call activation
	N.O. = N/O contact	Normally open contact	
	N.C. = N/C contact	Normally closed contact WARNING! If unused, the contact should not be opened!	
CANCEL terminal	voltage control *)	5 - 24Vdc, any polarity **)	Emergency call deactivation upon door opening
	contact control	any contact **)	

*) For safety reasons, these terminals are electrically isolated from the telephone line.

**) You need not do anything to activate ALARM if you keep the factory settings. For deactivation, voltage application or contact closing is necessary. To change the settings use parameter 916 for ST and the rotary switch for LN.

Connectors

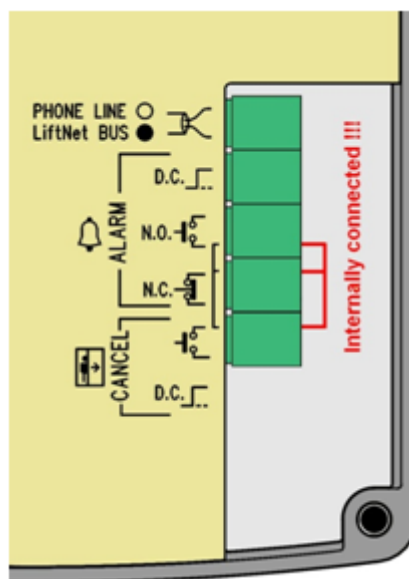

Figure: Connectors of Lift Cabin Audio Unit – Compact (Later HW)

⚠ Warning

- Make sure that the button is safe, i.e. that the minimum isolation distance is 1.5 mm and the minimum breakdown voltage value is 1,500 V. The button contacts may not be connected to any other circuits. If any of the above conditions cannot be met, use voltage control.
- You can use an N/O or N/C button or both.
- Refer to the rear cover for internally connected terminals – see Fig. 2.13.

ALARM Button Connection with N/O Contact

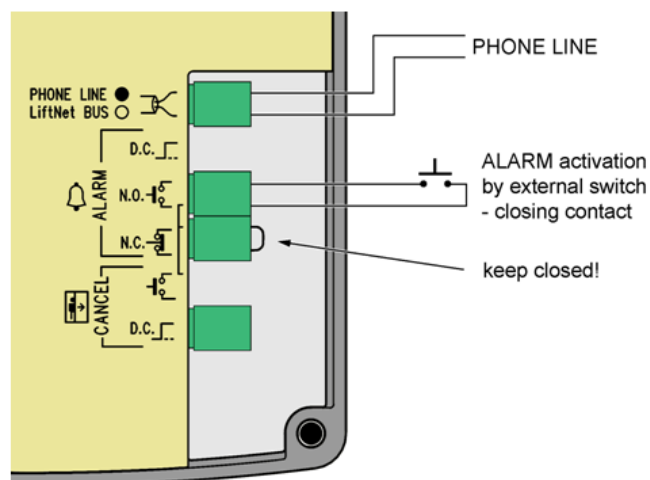

Figure: ALARM Button Connection with N/O Contact

ALARM Button Connection with N/C Contact

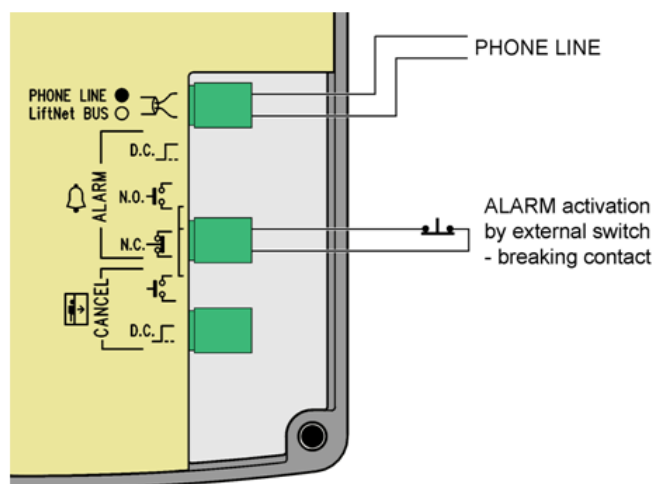

Figure: ALARM Button Connection with N/C Contact

Note

- The ALARM button mounted on the cover is still functional when an external button is connected.

Voltage Activation

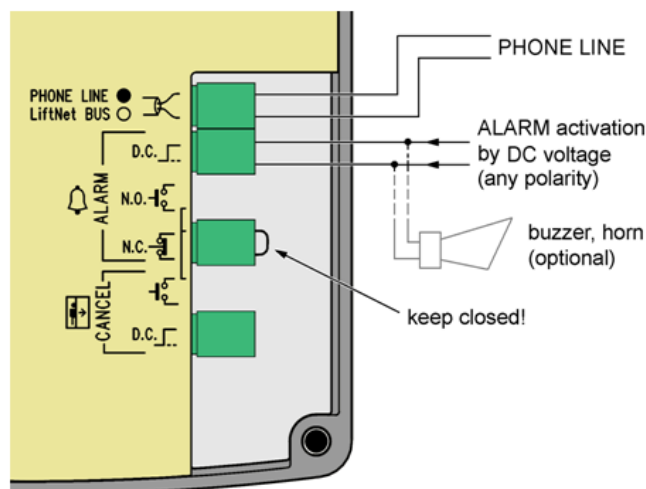

Figure: Voltage Activation

⚠ Caution

- 5 - 24 dc voltage of any polarity can be used. Make sure that the power supply is backed up properly.
- Where activation from multiple places is necessary, voltage control can be combined with buttons.
- A buzzer or horn can be connected in parallel, see the figure to the right.

Inversion Voltage Control

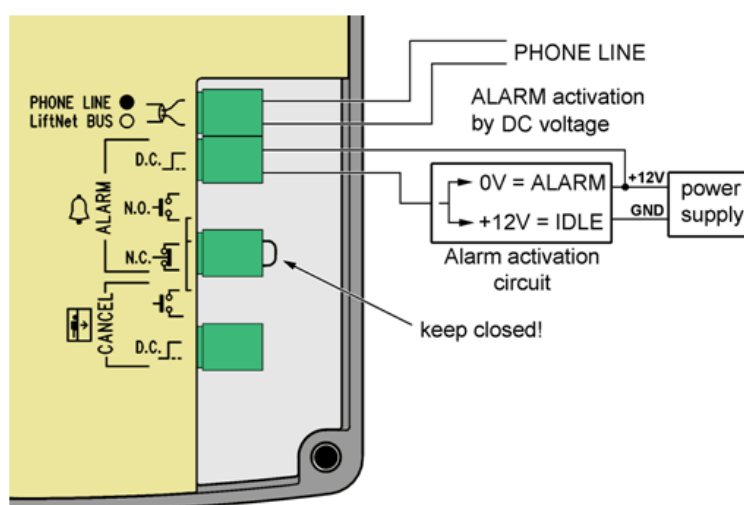

Figure: Inversion Voltage Control

The figure to the right shows a configuration where voltage is present and activation is caused by non-presence of voltage.

Bus Connection

The connection polarity is arbitrary.

Warning

- Connection to different, e.g. higher-voltage, cables leads to damage or destruction of the audio unit.

Caution

- Avoid the audio unit address duplicity.

CANCEL Input Connection (Door Contact, Optional)

This input helps cancel a rescue request if the lift is fully functional. When the ALARM button is pressed, the system waits for a pre-programmed period of time, which is a little longer than the maximum lift running time. If the lift is functional, it arrives in the required station within this timeout and opens the door. In that case, the rescue request is cancelled. If the door fails to open, the request is accepted.

Make sure before installation that the "door open" signal is available in the lift cabin.

Requirements

- In double-door lifts, the signal has to be active only if both the doors open successfully and let the people out.
- The door position signal has to work even in the case of power outage.

Contact control

Requirements

- None of the CANCEL terminals may be connected electrically with any other electrical circuit and a voltage source other than the contact.

Instructions

1. Connect the CANCEL terminal into upper position.
2. Make sure that the switch position matches the door contact configuration (open or closed when the door is closed) - see Address setting.

Voltage control

Requirements

- DC 12 to 48V voltage

Instructions

1. Connect the CANCEL terminal into lower position.
2. Make sure that the switch matches voltage presence or absence when the door is closed - see Address Setting. Voltage presence corresponds to a closed contact; voltage absence means an open contact.

Warning

- Ignoring the instructions above may lead to product damage.

Note

- Remember to program delayed calling to make the CANCEL connection work successfully.

Mounting Completion

Connect the wires before wall mounting. The connectors are separable - remove them, connect the wires, tighten the screws and replace the connectors.

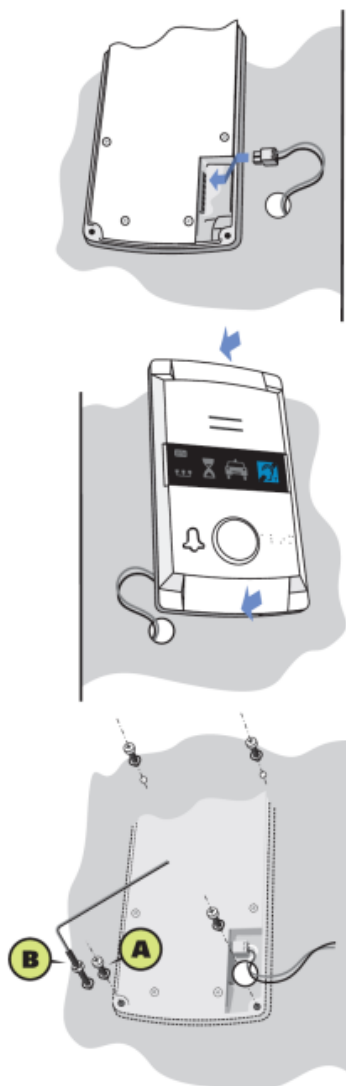

Figure: Lift Cabin Audio Unit – Compact Mounting

Mounting the audio unit from the outer lift cabin wall is easier. In that case, no screws are accessible from the lift cabin and the audio unit cannot be stolen. If the cabin wall is accessible from the outside, follow the instructions in item a) or b). If not, follow item c).

1.
 - a. If the lift cabin wall is thin (stainless steel sheet), seek four 8 mm long M4 screws and fan-shaped washers in the accessories.
 - b. If the lift cabin wall is thick (up to 20 mm – laminated chipboard), seek four headless, 30 mm long M4 screws. Screw them into the unit backside using the wrench included in the delivery and tighten properly. Then push the assembly through the pre-drilled holes, insert the fan-shaped washers from the back and screw in the nuts.

-
- c. If the lift cabin wall is inaccessible from the rear, follow instructions on the
n e x t p a g e .

***TIP:** If you have pre-drilled corner holes, find four headless M4 screws of the length of 30 mm in the package. Drive the screws into the holes on the rear side of the audio unit and tighten as mentioned in item b) above. Though unequipped with nuts, the screws fix the product reliably, preventing it from sliding or turning.*

Induction loop connection

The induction loop for people with defective hearing is included in the product, no other loop is needed.

Mounting Completion - without Rear Access

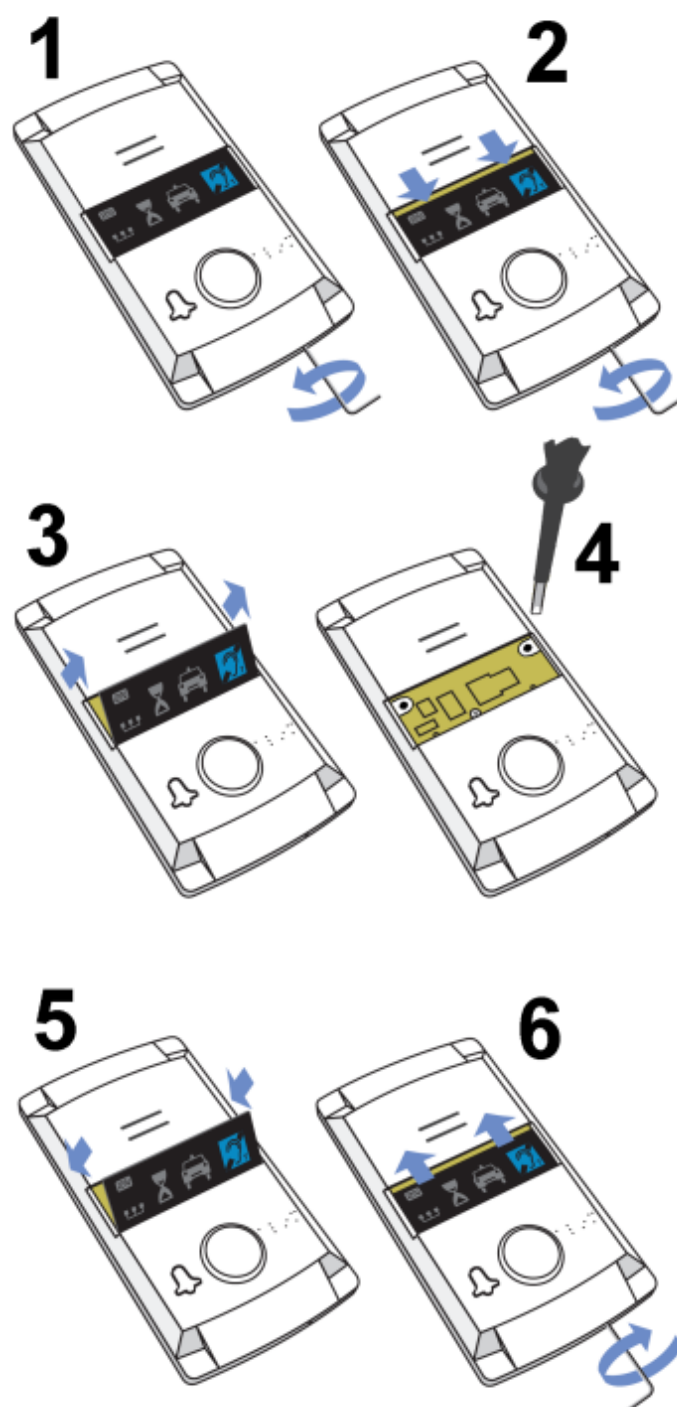

1. Insert the hex wrench (included in the delivery) in the bottom unit edge hole; turn **left** about 10 times until it puts up resistance.
2. The window slides down by itself or with little assistance, showing its upper brim.
3. Tilt the window forwards and remove.

4. Now you have access to two holes in the window corners. Put unit (including the connected wires) on the pre-drilled lift cabin wall. Drive and tighten the included screws for plywood, chipboard, laminated plastic etc. wall mounting or short M4 screws with fan-shaped washers (intended for metal plate mounting with pre-drilled M4 threaded holes).
5. Replace the window.
6. Insert the hex wrench (included in the delivery) in the bottom unit edge hole, turn **right** about 10 times until the window slides under the panel edge and tighten applying light force.

2.4 Audio Unit - Machine Room

Description

This audio unit is designed for machine room installation. Compared with the other types, it has some unique features:

- The audio unit contains a telephone set with the HandsFree/receiver modes for good function in a noisy environment.
- The attached telephone is equipped with a keypad for function selection and **system programming**.
- The attached telephone **does not ring**. The audio unit is equipped with a siren that is loud enough for a noisy environment.
 - The machine room audio unit can be shared by multiple lifts.

The audio unit is equipped with a lift blocking contact in case LN fails to call for help.

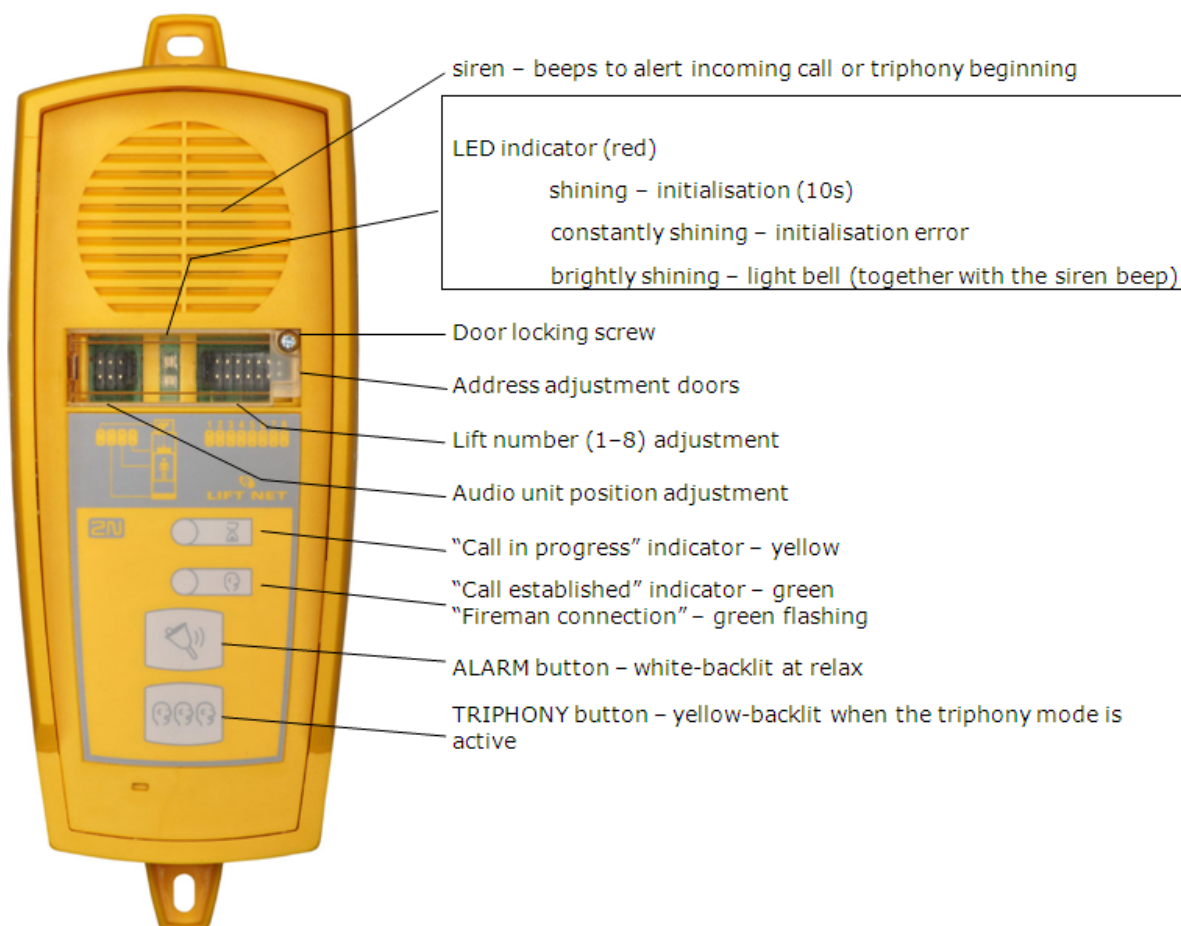

Operating instructions

This unit may only be used by authorised persons such as the lift maintenance staff.

The TRIPHONY button activates voice communication between all units with the same lift number.

The ALARM button can be used for calls to the dispatching centre. The ALARM button backlight (not required by standards) allows you to find the unit in a dark environment.

In both cases, it is necessary to pick up the attached phone.

If the attached phone is picked up and neither ALARM nor TRIPHONY is pressed, you can make use of other functions; refer to the machine room voice menu.

Before You Start

Requirements

- Be sure to connect the telephone set included in the audio unit delivery. No other telephone type may be used except with the consent of the manufacturer.
- The lift control circuit must be equipped with a function blocking input in case the LN is unable to provide connection with the dispatching centre.

Product completeness check

Check the product for completeness before installation please:

- 1 audio unit
- 1 telephone set (a separate unit including accessories and the manual)
- 2 wall dowels
- 2 dowel screws
- 7 address setting jumpers

Mounting

Typically, the audio unit including a telephone set is mounted onto a wall using available dowels and screws. The recommended machine-telephone distance is approximately 10 cm. The maximum distance is determined by the interconnecting cable delivered together with the telephone.

Electric Installation

Description of connectors

Release the screw on the right-hand side and open the connector cover. There are three connectors:

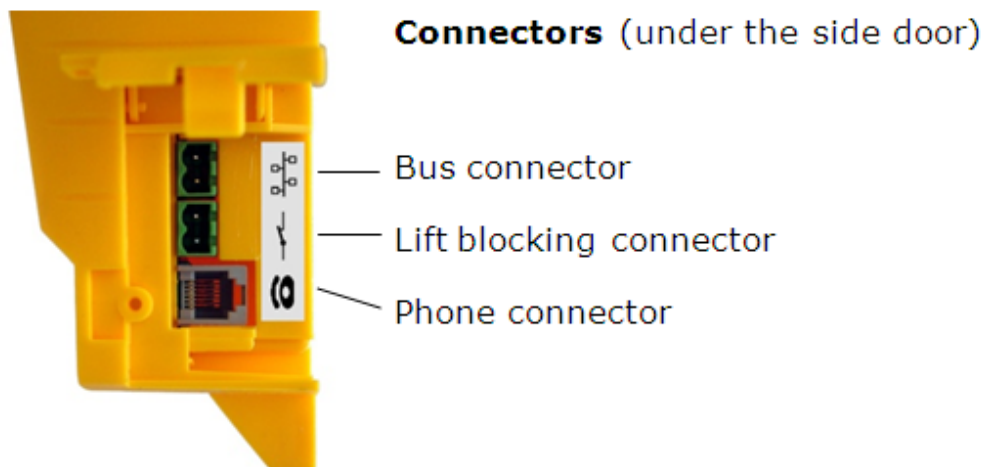

Address Setting

There are two groups of jumpers under the transparent front cover. For their meanings see the printing located directly under them.

- Left-hand group of 4 jumpers: leave them in the "machine room" position.

Note

- You can set another position too - if, for example, you want to have a classic telephone and thus program the CU on the shaft bottom, you can use this audio unit and set the jumper into the appropriate position.

- Right-hand group of 8 jumpers: address setting. If the machine room is shared by multiple lifts, you can use one audio unit and set more addresses with the available jumpers. This is impossible with other types of audio units!

Note

- If more addresses have been set in the audio unit, press the TRIPHONY button to activate communication with the lift with the lowest address.

Caution

- Avoid the audio unit address duplicity.

Bus Connection

Remove the terminal board from the connector, connect the wires and replace the terminal board. The connection polarity is arbitrary.

Warning

- Connection to different, e.g. higher-voltage, cables leads to damage or destruction of the audio unit.

Caution

- The unit is powered via a 2-wire bus from the central unit. Unplugging of the bus from the CU causes switching off of the unit.

Telephone Connection

Use the telephone set including the cable with telephone terminals that are part of the audio unit delivery.

Caution

- The audio unit is not functional without a telephone set connected.
- Connecting a telephone set of different type may result in difficulties, such as system failure.

Testing

To test the function, pick up the handset. If no other call is currently being made, you can hear the machine room voice menu.

Lift Blocking Function Connection

Caution

- This function may be mandatory if the local applicable regulations require so at the time of installation.

Blocking procedure: the contact opens whenever a telephone line fault is detected or the LN batteries are low. Connect the contact to the appropriate controller input of the lift or a group of lifts. The control electronics shall ensure that, upon contact opening, the lifts that are in operation arrive in the nearest station and open the door. If the audio unit is shared by multiple lifts, all lifts must stop the function identically.

2.5 Audio Unit - Lift Shaft - Cabin Roof

Description

This audio unit is designed for installation on the lift shaft bottom or lift cabin roof, or similar places where communication is needed during lift maintenance, for example. The audio unit is enclosed in a robust yellow cover. It is not intended for outdoor use but perfectly fits in lift shafts - is resistant against fall of small objects, dripping oil, etc. The ALARM button activates the dispatching centre connection, the TRIPHONY bottom enables conference connection with the other audio units of one and the same lift. The audio unit contains a built-in microphone and a loudspeaker. Thanks to its size and robustness, the audio unit features a very good sound.

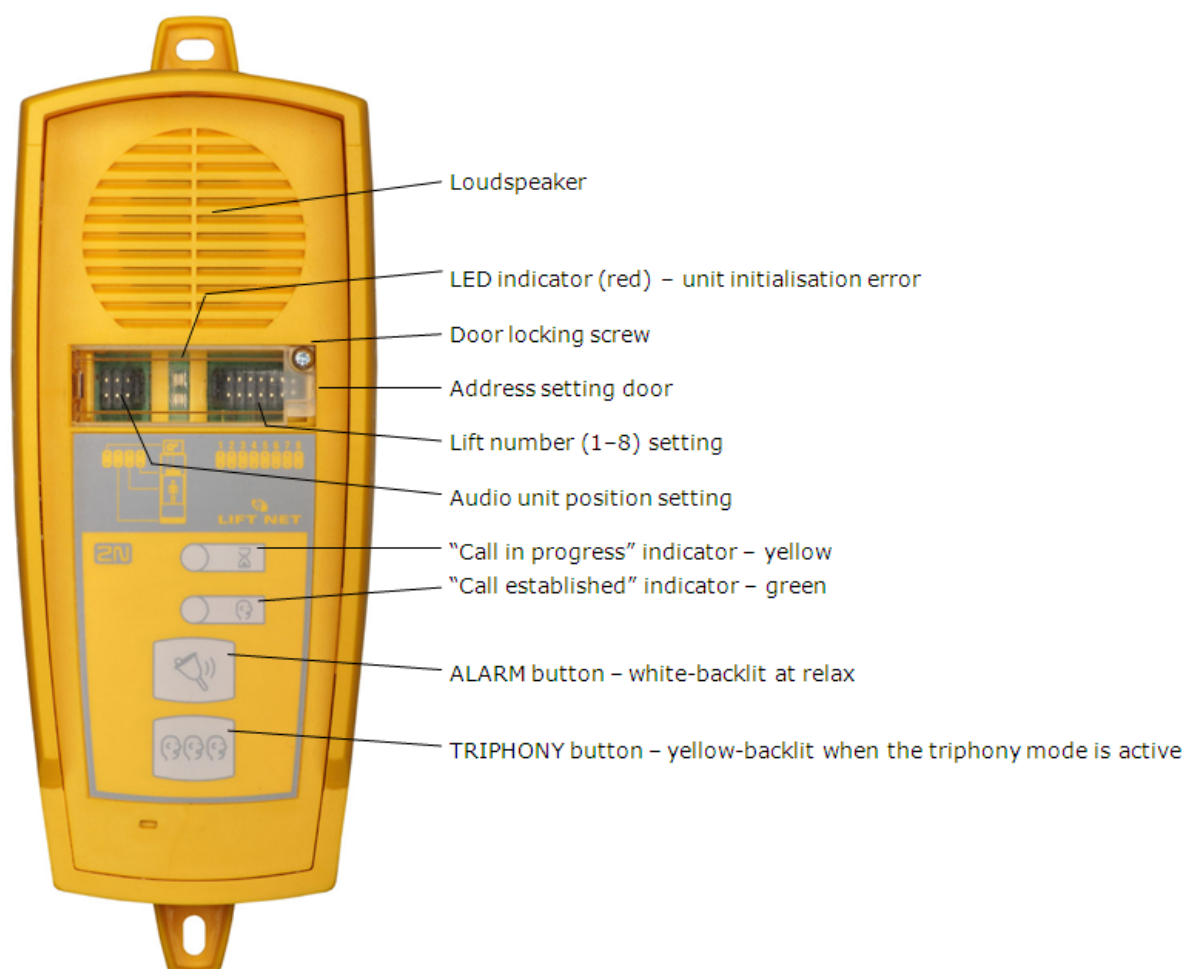

Operating instructions

This unit may only be used by authorised persons such as the lift maintenance staff.

The TRIPHONY button activates voice communication between all units with the same lift number.

The ALARM button can be used, for example, when somebody falls into the shaft. The ALARM button backlight (not required by standards) allows you to find the unit in a dark environment.

Before You Start

Product completeness check

Check the product for completeness before installation please:

- 1 audio unit
- 2 wall dowels
- 2 dowel screws

Requirements

There are no special requirements for this unit type.

Caution

- This audio unit is not designed for lift cabins.

Mounting

Typically, the audio unit is mounted onto a wall using the dowels and screws included in the delivery. Find the drilling pattern on the product package.

Caution

- The audio unit is not designed for outdoor applications.

Electric Installation

Connectors

This unit has only one connector (bus) under the side door.

Address setting

The audio unit address means setting of two jumpers, namely the lift number (1 to 8) and audio unit position (refer to the cover drawing). If you install the audio unit on the shaft bottom of lift 1, you need not change the jumper configuration. Otherwise, follow the instructions below:

Instructions

1. Release the screw on the jumper window cover and open the window.
2. Configure the required changes as printed below the window (this audio unit cannot be shared by multiple lifts).
3. Close the window and tighten the screw.

Warning

- Avoid the audio unit address duplicity.

Connection

Relase the screw on the right-hand side and open the connector cover. There is just one connector – for bus connection. Remove the terminal board from the connector, connect the wires and replace the terminal board. The connection polarity is arbitrary.

Warning

- Connection to different, e.g. higher-voltage, cables leads to damage or destruction of the audio unit.

Caution

- The unit is powered via a 2-wire bus from the central unit. Unplugging of the bus from the CU causes switching off of the unit.

3. Configuration

This section describes programming of 2N[®] LiftNet. It is possible to program 2N[®] LiftNet in three ways.

- 3.1 LN Programming
- 3.2 Parameter Chart (FW v. 1.9.1)

3.1 LN Programming

The advantage is that it is only the CU that has to be programmed. Thus, it is unnecessary to re-program the parameters after audio unit replacement. With a multiple-lift system, you just program one CU. The memory is independent of the CU power supply.

To program the CU choose one of the following three ways:

1. Remote (PSTN) telephone programming	The access is password-protected. The voice menu is in the national language.
2. Machine room telephone programming	
3. PC USB programming	Use 2N [®] LiftManager including the Service Tools. Also, you can use the firmware upgrade, download of language mutations and user-recorded message.

PSTN Programming

Before You Start

- Make sure that your telephone enables tone dialling (troubles may occur with the so-called system/key telephones in some PBX systems).
- Prepare a list of all parameters to be programmed in advance.
- Make sure that, if LN is not entirely new, the service password is correct and, if you are not quite sure of your LN configuration, execute full initialisation.

Caution

- Remember to initialise the service password too!

Entering Programming Mode

You can enter the programming mode only during an incoming call (PSTN call to LN) or upon line seizure by the machine room telephone.

To enable the programming mode press to enter services and after that enter the service password in the format:

 service password 

 **Note**

- Remember to enter an asterisk before and after the password!

If the password is correct, LN reports "You have entered the programming menu" and displays a context-dependent help. The default password is **12345** and you have a 5-second timeout by default (or a user-defined limit of 1 to 9 seconds) to enter every character of your password. If you fail to keep the timeout, LN hangs-up.

 **Note**

- You are recommended to change it to secure your equipment against unauthorised access.

If you forget your password, contact the manufacturer to recover your data.

Programming Procedure

Having entered the programming mode, you can change any programmable value(s) in any order. Proceed as follows: enter the function number and then the value. Use an asterisk as a separator or Enter. In general, the function has the following format:

function number  value 

The function number has three digits (see the table). After you enter the function number and an asterisk, LN reports the number or name, current value and potential range of the parameter to be programmed. After you enter the value and another asterisk, LN reports "Value stored", or "Invalid value" if the value is beyond the allowed range.

 **Warning**

- A drawback of some telephone sets is that, after you press a button, i.e. send a DTMF signal, they go "deaf" for a fraction of a second. In that case, you cannot hear the whole text and are recommended to use another telephone.



Programming Error

If you make a mistake during entering (the function number or value) and have not entered an asterisk yet, you can cancel the whole number by pressing  and re-enter the digits.

If LN rejects a parameter number or value you have entered, go on programming but re-enter the function number even if it was the value not the number that was wrong.

If you have programmed and stored a value other than you intended to, you can re-enter the value of course.

Programming End

Having stored all values to be changed, terminate programming by pressing . LN sends a hang-up signal and hangs up. If you do not use the  character, LN hangs up later without affecting the stored values (the values are stored immediately after being entered).

If you are not quite sure of LN's programming behaviour, save the filled-in form for later check.

Troubleshooting

LN fails to respond correctly to DTMF commands, e.g. the programming mode cannot be entered.

Today, voice transmission is prevalingly digital, using variable compression algorithms. Therefore, the DTMF signal to be transmitted is often distorted. Moreover, it may, in some cases, be transmitted through the so-called command channel, whose delay may differ from that of the speech channel.

Caution

- Experience shows that, especially recently, it is practically impossible to recover the DTMF signal in GSM networks

In such cases, try some other equipment (a digital PBX, e.g.) or the machine room telephone set. If the machine room or PSTN programming attempts fail too, you have probably entered an invalid password.

3.2 Parameter Chart (FW v. 1.9.1)

Explanatory notes:

Grey = future features

Par. No.	Parameter Name	Range	Default	Note
011	ALARM button memory 1	up to 16 digits 0 - 9	blank	Entering characters * and # will be able by PC programming.
012	ALARM button memory 2	up to 16 digits 0 - 9	blank	
013	ALARM button memory 3	up to 16 digits 0 - 9	blank	
014	ALARM button memory 4	up to 16 digits 0 - 9	blank	
015	ALARM button memory 5	up to 16 digits 0 - 9	blank	
016	ALARM button memory 6	up to 16 digits 0 - 9	blank	
017	Adding of a special symbol *, # and "delay"	<p>Entering format: XX7 * XX XX *</p> <p>Button number, 01 _____</p> <p>1 = * 2 = # 3 = space _____</p> <p>Button memory number, 1 – 6 _____</p> <p>Character position, 01 - 16 _____</p> <p><i>Note: The digits behind this position are shifted automatically.</i></p>		
018	Count of automatic dialling cycles for ALARM	0 - 9	3	
019	Automatic dialling type for ALARM	0 - 3	1	0 = off (1 number from memory 1 is dialled) 1 = with DTMF confirmation 2 = with GSM confirmation 3 = no confirmation (count of rings)
071	Checking call memory 1	up to 16 digits 0 - 9	blank	If let completely blank, ALARM memory 1 to 6 is used for the checking call.
072	Checking call memory 2	up to 16 digits 0 - 9	blank	
073	Checking call memory 3	up to 16 digits 0 - 9	blank	
074	Checking call memory 4	up to 16 digits 0 - 9	blank	
075	Checking call memory 5	up to 16 digits 0 - 9	blank	

Par. No.	Parameter Name	Range	Default	Note
076	Checking call memory 6	up to 16 digits 0 - 9	blank	
077	Adding of a special symbol *, # and "delay"	<p style="text-align: center;">Entering format: XX7(*)XX(*)</p> <p>Button number, 07 _____</p> <p>1 = (*) 2 = (#) 3 = space _____</p> <p>Button memory number, 1 – 6 _____</p> <p>Character position, 01 - 16 _____</p> <p><i>Note: The digits behind this position are shifted automatically.</i></p>		
078	Count of automatic dialling cycles for checking call	0 - 9	3	
079	Automatic dialling type for checking call	0 - 3	1	see parameter 019
906	Delay after digit dialling	cannot be changed	100ms	The parameter cannot be changed. It gives the delay between the digit dialling and voice message start.
909	Timeout for dialling tone detection	1000 – 9999 ms	5000 ms	LN waits for the dialling or continuous tone for this period of time. If it fails, the line is defective.
911	Count of rings before incoming call answering	1 - 9	2	Defines the moment of picking up (for incoming calls).
912	Max. call duration	10 – 1000 s	120 s	Call can be prolonged by command.
913	Timeout for call confirmation	10 – 1000 s	60 s	LN waits for confirmation for this period of time (outgoing call, automatic dialling with come confirmation enabled). If it fails, LN hangs sup and proceeds to the next number. Measured from the dialling end.
914	Delayed call	0 – 1000 s	0 s	Applicable only if the CANCEL input is used (913610E unit only).
915	Max. TRIPHONY duration	10 – 9999 s	7200 s	
917	On-hook time between calls	500 – 9999 ms	5000 ms	
918	Max. time of telephone line test	1 – 20 s	5 s	A line test (dialtone test) is made every 11 minutes. If the dialtone is missing in three subsequent tests, the lift gets blocked. When the line is recovered, the lift gets unblocked automatically.
920	Call confirmation command	cannot be changed	1	Mutes the message too.
921	Message muting command	cannot be changed	2	

Par. No.	Parameter Name	Range	Default	Note
922	Repeat message command	cannot be changed	3	
923	DTMF identification command	cannot be changed	6	Mutes the message too.
924	Call prolongation command	cannot be changed	4	The call is prolonged by the time set in parameter 912 again.
925	Call end command	cannot be changed	5	
930	Shaft audio unit loudspeaker volume for TRIPHONY	1 - 10	10	Used for echo cancelling between the audio units if any in TRIPHONY.
931	Cabin audio unit loudspeaker volume for TRIPHONY	1 - 20	10	The volume range is 1-20 for all cabin audio units (931). However, the actual maximum is 10 for the Compact unit and earlier HW cabin units (new cabin audio units are louder than the older types).
932	Cabin audio unit loudspeaker volume for alarm and incoming calls	1 - 20	10	Used for alarm and incoming calls. The volume range is 1-20 for all cabin audio units (931). However, the actual maximum is 10 for the Compact unit and earlier HW cabin units (new cabin audio units are louder than the older types).
933	Receiving volume	1 - 10	10	For incoming and outgoing calls from/to PSTN.
934	Transmitting volume	1 - 10	10	For incoming and outgoing calls from/to PSTN.
940	Minimum dialling tone time	200 - 2000 ms	400 ms	Must be longer than the busy tone duration!
941	Minimum continuous tone time	200 - 9999 ms	2000 ms	LN hangs up if the continuous tone is detected (not before dialling).
942	Minimum busy tone period	100 - 500 ms	200 ms	These parameters control the busy tone detection. They are used for call termination and automatic dialling.
943	Maximum busy tone period	200 - 1600 ms	800 ms	
944	Maximum tone - space difference (for busy tone)	10 - 400 ms	50 ms	
945	Minimum count of busy tone periods	2 - 50	5	
946	First dual tone frequency	300-700Hz	370Hz	Parameter modification for British dual tone detection.
947	Second dual tone frequency	300-700Hz	440Hz	Parameter modification for British dual tone detection.
951	Minimum ringing tone time	50 - 2000 ms	500 ms	The ringing tone time is integrated across the ringing tone parts that are not separated by a long delay.
952	Minimum long space time (for ringing tone)	100 - 5000 ms	1000 ms	The longest ringing period delay must be in the interval between parameters 952 and 953.
953	Maximum long space time (for ringing)	500 - 9999	6000 ms	CAUTION! Parameters 951 - 953 are used (by default now) for ringing detection (incoming

Par. No.	Parameter Name	Range	Default	Note
	tone)	ms		calls).
961	Maximum timeout for pressing the next digit	1 - 100 s	10 s	During password entering, programming, etc.
962	Minimum time of pressing ALARM, for cabin units	10 - 9999 ms	100 ms	A short time set temporarily for easier testing.
963	Minimum time of pressing ALARM, for other units	10 - 9999 ms	100 ms	
964	Minimum active CANCEL input time	10 - 9999 ms	100 ms	
968	Machine room alerting tone (siren)	1 - 60 s	1 s	Temporarily a single tone, 1 s long. There is a future possibility to start alerting the moment an incoming ringing is detected. When the call is answered in the machine room, the voice menu will be cancelled.
970	Identification type for ALARM calls	1-2	0	1: LN identification on (incl. audio Id) 2: LN identification equal to ST identification (without parameter YY - audio unit Id)
973	Language for numeric messages	0 - 1	1	0 = User recorded 1 = English
974	Lift identification	up to 16 digits 0 - 9	blank	The number enables lift identification for foreigners, for example. Also used for automatic call handling (2N [®] LiftManager). If blank, the serial number is reported.
975	Local message sequence	Up to 8 messages (each has 2-digit ID)	blank (=22)	It allows playing back messages in more languages in the defined sequence, including the identification number, etc. 01 = User message #1 02 = User message #2 03 = User message #3 04 = User message #4 05 = User message #5 06 = User message #6 07 = User message #7 08 = User message #8 09 = User message #9 10 = User message #10 11 = Serial number 12 = Lift identification number (par. 974) 13 = Lift shaft number (1 - 8) 14 = Audio unit number (1 - 4) 15 = "Serial number" 16 = "Identification number" 17 = "Lift number" 18 = "Audio unit number" 19 = DTMF sequence defined by parameter 970 20 = 2s delay 21 = 🎵 (confirmation tone)
976	Outgoing message sequence	Up to 8 messages (each has 2-digit ID)	blank (=2324)	

Par. No.	Parameter Name	Range	Default	Note
977	Checking call sequence	Up to 8 messages (each has 2-digit ID)	blank (=2829 1612)	22 = "Wait please, connection is being established" 23 = "This is an emergency call" 24 = "Press 1 for connection with the lift cabin" 25 = " Press 1 for connection with the lift" 26 = Outgoing DISA ("Press 1 for connection with the lift cabin. Press 2 to mute the message. Press 3 to repeat the message. Press 5 to terminate the call.") 27 = "Connection confirmed" 28 = "This is a checking call" 29 = "This is communicator ..." Cautions: 1) User messages #1 to #10 are recorded into the CU with the aid of Service Tools 2) "" = voice message 3) DTMF sequence (2N protocol) Format: *X*Y Y*ID(par.974)*checksum# X=1 - Alarm, 2 - Checking call YY=00 - Checking call, SA - shaft + audio unit ID (e.g. SA=11 means shaft 1 and cabin audio unit)
978	Sequence of messages upon call confirmation by button 1	Up to 8 messages (each has 2-digit ID)	blank (=27)	
979	Sequence of messages for dispatching upon pressing of button 3	Up to 8 messages (each has 2-digit ID)	blank (=1612 171318 14)	
981	Checking call	0 - 4	0	0 = off 1 = checking call in 1 minute 2 = on, first call in 2 hours 3 = on, first call in full period time 4 = on, checking call according to parameter 986 (Days in week) CAUTION! Each of the values switches on periodic checking calls, the period is the same, <u>only</u> the first call time is different.
982	Checking call interval	hhmmssmm	00002359	Allows to force a checking call e.g. at night (lower fee).
983	Checking call period	0 - 100 days	3 days	0 = OFF (however, setting parameter 981 to 0 has the same effect).
984	Time adjustment	hhmmss or hhmm	blank	Necessary if the Checking call interval is used (can only be set via the voice menu; synchronisation with the PC time is made via the Service Tool).
985	Date adjustment	xy.mm.dd	blank	Configure when parameter 986 is set to Days in week (upon a date change, the test call date is rescheduled according to the new date) (can only be set via the voice menu; synchronisation with the PC time is made via

Par. No.	Parameter Name	Range	Default	Note
				the Service Tool).
986	Days in week for checking calls	mtwtfss	blank	mtwtfss values 0 = do not call 1 = call M = Monday T = Tuesday W = Wednesday ... S = Sunday
990	System setting	0 - 1	0	0=active and rest bus statuses (for longer battery back-up in the event of power outage), 1 = active bus status only (higher Emi For long buses for noisy environment)
991	Service password	up to 16 digits 0 - 9	12345	
996	Fireman settings	XY	blank	Format XY X = shaft value as set in the Fire Station cabin audio unit (1-8) Y = define whether activation is made by a button (0, first press = activate, second press = deactivate), or using a key (1)
997	Firmware version			Identifies the firmware version, reading * instead of dots.
998	Automatic upgrade of audio units	0 - 1	1	If set to 1, the CU will automatically upgrade all connected audio units while booting up.
999	Full initialisation (including service password!)			Re-enter the valid service password as the function parameter (as protection against unintended deletion if you enter a false function number).

PC Configuration

For this purpose, install the 2N[®] LiftManager software on your PC. It consists of two parts:

1. Dispatching centre software. Allows for automatic receipt of checking calls and other dispatching functions. Requires a modem. Is limited to a few lifts only without licence.
2. Service tools. This part is fully functional without licences. Helps configure the LN, which is connected to the PC through a USB interface. Also enables to upgrade the firmware. At present, no remote PC configuration or upgrade are possible.

For more information, install and run 2N[®] LiftManager from the CD enclosed.

How to Record User Messages and Numbers

From a PC

To upload the user messages and numbers into the 2N[®] LiftNet device, you will need the Service Tools utility. To upload a message into 2N[®] LiftNet, please follow the three easy steps below:

1. Record your message using your PC soundcard and microphone. Save the voice message to the .wav file with the following parameters: 8bit, 8 kHz, MONO.
2. Upload the .wav files you have created into 2N[®] LiftNet using the Service Tools via the Device / User Messages Upload or User Numbers Upload menu.
3. Remember to enter all of the 10 (0 - 9) .wav files while uploading user numbers.

From a Telephone

Recording of a message from a telephone is possible during programming only (refer to the Configuration section). Message recording is password protected. The record quality depends on the phone quality and surrounding noise.

4. Function and Use

This section describes the basic and extending functions of the 2N[®] LiftNet product.

Here is what you can find in the section:

- 4.1 User Instructions
- 4.2 Dispatching Centre Instructions
- 4.3 Fireman Function
- 4.4 Function Description (for Advanced Users)

4.1 User Instructions

Audio Unit - Lift Cabin

The lift cabin audio unit is intended for lay users. Nevertheless, instructions can be placed in the lift cabin, e.g., to help the people trapped in the lift communicate with the dispatching centre.

Meaning of Symbols

- The yellow "Wait" symbol is on whenever a connection is being established with the dispatching centre.
- The green symbol is on whenever a connection has been established and confirmed by the dispatching centre.
- The yellow "Triphony" symbol is on whenever triphony is in progress.
- The blue indicator is off but designates the signal sending place during the call for people with defective hearing equipped with hearing aids.

Audio Unit - Lift Shaft / Cabin Roof

- Press the ALARM button to call the dispatching centre.
- Press the TRIPHONY button to call the other audio units in one and the same lift.
- Repress the TRIPHONY button to terminate such connection.
- The ALARM button is shining at the relax state.
- The TRIPHONY button is shining while triphony is in progress.
- The yellow LED is shining while a connection with the dispatching centre is being established.
- The green LED shines to indicate that the connection has been established and confirmed by the dispatching centre.

Audio Unit - Machine Room

The shaft audio unit description applies to this audio unit too. To activate any voice function, pick up the receiver of the connected telephone, or enable the HandsFree mode on the telephone.

Machine room voice menu

When you pick up the phone in the machine room, you can set other functions available in the voice menu using the phone keyboard.

Choose the lift number by pressing 1 to 8.

For connection with the lift cabin choose 1.

For the machine room choose 2.

For the shaft bottom choose 3.

And for the cabin roof choose 4.

Press 9 for services.

Enter the service password. Press 5 to end the call.

 **Note**

- Number 9 is primarily used for LN configuration - refer to the Configuration section.

4.2 Dispatching Centre Instructions

ALARM Call

1. The process starts the moment the ALARM button is pressed on any audio unit. Upon the press, LN calls the dispatching centre (refer to Automatic Dialling for details).
2. When the incoming call is answered by the operator, the LN voice message is played identifying the calling lift.
3. The answered call must be manually confirmed first. This is done by button 1 on the dispatcher's phone.
4. The call is time-limited (by the "Attention, the call is ending" message), but can be prolonged using the button 4.
5. You are recommended to terminate the call by pressing button #.

Dispatching Centre - Lift Call

The dispatching office may call back to LN. The CU receives any incoming call automatically, identifies itself and offers a voice menu (DISA). This helps the caller to access the required audio unit. Like outgoing calls, incoming calls are time-limited and easily controlled (prolongation, end).

Incoming call voice menu

Hello! This is communicator ID number.../serial number...

Choose the lift number by pressing 1 to 8.

For connection with the cabin choose 1.

For the machine room choose 2.

For the shaft bottom choose 3.

And for the cabin roof choose 4.

Press 9 for services.

Enter the service password. Press 5 to end the call.

The above mentioned menu helps you call the selected audio unit.

Notes

- The machine room connection, however, is possible only if the connected telephone has been picked up.
- Number 9 is primarily used for LN configuration - refer to the Configuration section.
- Where the LN identification code is not stored, LN announces its production/serial number.

ALARM Call - Intercom

1. The process starts the moment the ALARM button is pressed on any audio unit (except for the pre-set machine room - dispatching centre unit). Upon the press, LN calls to the pre-set machine room - dispatching centre audio unit (refer to Automatic Dialling for details).
2. When the incoming call is answered by the operator, the LN system voice message is played.
3. The answered call must be manually confirmed first. This is done by button 1 on the dispatcher's phone.
4. Then, the voice connection with the calling audio unit is activated.
5. The call is time-limited (by the "Attention, the call is ending" message), but can be prolonged using the button 4.
6. Press 5 or # (or hang up, but this termination takes a longer time) to terminate the call.

Caution

- No alarm call can be made from the machine room audio unit set as the dispatching centre. The alarm call is set to the audio unit that was the last to activate the Alarm function. If no alarm was activated on any audio unit, the machine room audio unit sets up no call.
- If a call is set for a non-existent machine room audio unit, the alarm call is not established (valid for settings #9, #0). If more numbers than one are pre-programmed, the non-existent audio unit is skipped.
- **Alarm - Intercom setup.** During the Alarm - intercom setup, there is unilateral audibility between the machine room audio unit and the alarm initiating audio unit at first and, when the call is confirmed, there is bilateral audibility.
- If you set #1 to #8 into the checking call memory (i.e. checking calls will be set up to the machine room audio unit), it will be impossible to initiate alarm from the set audio unit.
- When the machine room audio unit - intercom is called, the voice message for the dispatching centre is played to the calling unit too.

Setting Machine Room Audio Unit Number

Enter # before the lift number to set the machine room number. For example, 011 - #8 means that calling to lift 8 machine room audio unit is set in ALARM button memory 1.

Setting options:

1. Service Tools - enter # and lift number into parameters 011-016.

ID	Parameter Name	Value
011	ALARM button memory 1	#8

2. Set the lift number into the button memory (011-016) in the programming menu, select parameter 017 (refer to the table of parameters) and enter the required character (#) into the appropriate button memory.

Caution



- The dispatching-intercom audio unit is set as lift 8 type machine room by factory default.
- You can set alarm-intercom for lifts 1-7 too. All you have to do is change the lift address (jumper) and set another number into the ALARM button memory.
- The dispatching centre audio unit must be of the machine room type and set as the machine room. If it is set otherwise (as a shaft, cabin or roof), no call to the unit will be successful.







Note

- It is possible to combine calling to the machine room (dispatching) audio unit with calling via the PSTN.
- To set up a checking call to a machine room audio unit, you can set the number as described in the Alarm - Intercom subsection above.

Tone Dialling Control during Call - Complete List of Commands

Where automatic dialling with confirmation is used, it is possible to use tone dialling for LN control during the call according to the table below. For simplification, commands 1 to 5 are arranged in the sequence they are usually used in.

DTMF char	FUNCTION details
	Only where automatic dialling repetition is enabled. The character is used to confirm a successful call to LN. LN mutes the played-back message and, optionally, sends the identification code (DTMF). The call goes on until the timeout end and any of the following commands may be used.
	Voice module muting. CAUTION: Now this function is no more necessary for calling due to a software change.
	Repeated voice module playback, for 1 replaying of the message.

	<p>Call prolongation: The call is prolonged as defined in parameter 912 (120 seconds by default) in case it ended earlier without this command. May be used repeatedly.</p>
 or 	<p>Call termination.</p>
	<p>LN identification (without confirmation). This command is used by automated workplaces. The LN sends the identification code.</p>
	<p>The car audio unit is muted for 5 seconds during Alarm call (one-way communication from operator / dispatcher to car). This feature is mainly intended when big noise is in car (e.g. children crying) and operator needs to communicate whole information to person in cabin.</p>
 to 	<p>These digits are reserved for other commands, e.g. „rescue confirmation“.</p>

This table applies to the Automatic Audible Dialling with Confirmation mode.

 **Warning**

- Rarely, LN may not identify the above listed commands reliably during message playing or voice communication. This is due to the essential principle of the telephone line function where DTMF signalling is mixed with the talk and thus may be hidden behind some speech tones or noise. Hence, this phenomenon is not a defect of the product.

4.3 Fireman Function

Intended for firemen's actions, the Fireman function helps establish calls with the highest priority. Connection is established between the Fire Station and the cabin audio unit.

Description

The Fire Station is a universal cabin audio unit pre-programmed for the Fireman function. Install the Fire Station into a place that is easily accessible by firemen.

The fire call has the highest priority, interrupting all the other calls (refer to the Call Sequencing subsection). It is set up to the cabin audio unit in the shaft with the lowest address (shaft number).

Press the button or turn the key to set up the fire call. The call time is indefinite. Repress the button or return the key to interrupt the call.

A fire call setup is signalled by the fire station LED. Yellow light means the call setting process and green light means a successfully set-up call.

If the machine room audio unit set as the dispatching centre is used, the green LED starts flashing to indicate the fire call. Pick up the phone to enter the call. Hang up to leave the call without interrupting the fire call.

Caution

- The fire call has the highest priority and suspends all the other calls.
- The fire call is set up to the cabin audio unit in the shaft with the lowest address (shaft number).
- Fireman is a licensed function. Contact your local distributor for details.
- The fire station may be of the universal cabin audio unit type only.

Use

You can set up the fire call using a:

- **Button** – press the button to establish connection with the cabin audio unit and repress the button to cancel the connection.
- **Key** – turn the key ON to establish connection and return the key into OFF to discontinue the call.

Setting

Set the Fireman function using parameter 996 (format XY), where

X = the shaft number set on the Fire Station (1-8).

Y = activation this function with button (0), or key (1)

4.4 Function Description (for Advanced Users)

Purpose of Section

The purpose of this section is to help technicians solve problems, if any. If the system fails to work properly and a well-trained technician monitoring its operation step by step according to the description included herein gets to a point where the description and reality are in contradiction, he or she describes the contradiction, thus facilitating troubleshooting. This procedure often reveals that the system works properly but the user had a different idea of how to use it.

Outgoing Call

The process starts whenever the ALARM button is pressed on any audio unit. (in the lift cabin audio units, the CANCEL input may delay or block calling, refer to parameter 914). After the ALARM button is pressed, the LN, LN establishes connection with the dispatching office (for details see the Automatic dialling section). The LN replays a message identifying the LN and the calling audio unit, as well as the following instruction for the dispatching centre: "Press 1 for confirmation". The received call has to be confirmed manually or automatically. The call is time-limited (by the "Attention, the call is ending" message), but can be prolonged.

For (DTMF) control during a call see the Dispatching Centre Instructions subsection.

Machine Room Call

You can call any audio unit in one LN system from the machine room (i.e. from the machine room audio unit, item no. 913611, to which a telephone set is connected). Furthermore, you can activate functions and program LN parameters with the machine room audio unit. To activate the machine room audio unit, pick up the attached telephone. Using the TRIPHONY button you can get through to the other audio units of the same lift (however, if the machine room audio unit is shared by multiple lifts, triphony is activated in the first lift only).

Machine room voice menu

Choose the lift number by pressing 1 to 8.

For connection with the cabin choose 1.

For the machine room choose 2.

Choose the lift number by pressing 1 to 8.

For the shaft bottom choose 3.

And for the cabin roof choose 4.

Press 9 for services.

Enter the service password. Press 5 to end the call.

Triphony

Triphony provides interconnection of audio units. This mode can be activated by pressing the TRIPHONY button in the machine room (see the preceding subsection), in the lift shaft or on the lift cabin roof (audio units No. 913612E).

This mode features a different setting of the automatic HandsFree mode. The microphones of active audio units are less sensitive than those operating in the ALARM mode.

Triphony terminating options

- Machine room telephone hang-up;
- TRIPHONY button repressing;
- Timeout expiration;
- Giving priority to incoming or alarm calls.

Checking Call

The checking call is an automatically generated outgoing call, typically established every 3 days. The purpose of the checking call is to supervise the system function. Typically, this call is processed automatically in the dispatching office.

Incoming Call

The dispatching office may call back to LN. The CU receives any incoming call automatically, identifies itself and offers a voice menu (DISA). This helps the caller to access the required audio unit. Like outgoing calls, incoming calls are time-limited and easily controlled (prolongation, end).

If the operator calls back and wants to get connected to the audio unit from which the preceding call was made, enter 0 in the voice menu.

Incoming call voice menu

Hello! This is communicator ID number.../serial number...
Choose the lift number by pressing 1 to 8.
For connection with the cabin choose 1.
For the machine room choose 2.
For the shaft bottom choose 3.
And for the cabin roof choose 4.
Press 9 for services.
Enter the service password. Press 5 to end the call.

Call Sequencing

If another request arises during communication, the calls are queued. Calls have different priorities - alarm calls have the highest one. Therefore, the alarm call suspends any lower-priority call (the checking call, e.g.). Calls with identical priorities are queued and processed one after another. Having done that, LN recovers the suspended activity if possible.

Currently made:	Incoming call	Programming	Checking call	Alarm	Triphony	Fireman
New event:						
Incoming call	na	ns	na	na	S	ns
Checking call time	Q	Q	na	Q	Q	Q
Machine room telephone pick-up	ns	ns	ns	ns	Ns	Ns
TRIPHONY button pressing	ns	ns	Q	ns	Ns	Ns
ALARM button pressing	S	S	Q	Q	S	Q

Fireman	S	S	S	S	S	na
---------	---	---	---	---	---	----

Explanatory notes:

na = not applicable

ns= cannot be served

Q= to be queued









S= current activity suspended

Automatic Dialling of Multiple Numbers with Confirmation

Up to 6 telephone numbers including repetitions can be stored for dispatching office calling. LN then tries to call all the numbers stored. To confirm successful calls, LN uses tone dialling (DTMF). Having received a call manually, the dispatching office

officer has to press the  button on his or her telephone (tone dialling). If the called line is busy, or is unanswered within a timeout, or the call is not confirmed, LN dials the numbers in the sequence until it exhausts all pre-set attempts. The procedure is the same for checking calls or failure reports but a separate group of six numbers can be used.

Evaluation of Situations during Automatic Audible Dialling with Confirmation

Situation	LN Activity
Busy tone after number dialling end	LN hangs up and dials the next number in the sequence.
Call or silence	LN waits for a pre-set period of time (see Parameter 913).
Ringing tone	LN waits for a pre-set count of rings (see Parameter 954), then hangs up and dials the next number.
Continuous tone (on a PBX line, e.g.)	LN hangs up and dials the next number.
DTMF character  , or 	LN hangs up immediately and dials the next number.
DTMF character 	LN confirms receipt (2 beeps), mutes the current voice message and the call goes on for the maximum pre-set time (maximum call duration).
     	These digits are interpreted as control characters (refer to Subs.4.2).

Note

- The PSTN connection quality is not so high as to identify the above mentioned situations reliably in all cases. Moreover, excessive noise in the lift cabin may decelerate automatic dialling (due to inability to recognise the busy tone, e.g.). In general, DTMF is the most reliable type of signalling and so is used for confirming receipts. Thus, the connection is established (yet for a shorter time than usual) even in extreme cases, e.g. when LN cannot identify the DTMF.

Automatic Redialling of Multiple Numbers without Confirmation

This mode is useful where no trained personnel for automatic dialling with confirmation are available. The called party does not have to press any button. The two modes share a set of numbers, have an identical count of cycles, respond to the busy tone in the same way, etc.

The only difference is that the no-confirmation mode waits for the ringing tone and recognises that the called party has answered when the ringing tone terminates before the timeout end and that the connection has been made successfully.

In this mode, LN **does not** repeat the "Wait please" message (or any user-recorded message) after the dialling end, because it would be impossible to recognise ringing reliably. The message is played back once shortly after the called party answers. The message speaker **cannot** be controlled using buttons **1** to **5**.

Evaluation of Situations during Automatic Audible Dialling without Confirmation

Situation	LN Activity
Silence or busy tone after line seizure	This does not affect the operation. LN dials the first number under any line status and only then evaluates the situation.
Busy tone	LN hangs up in approx. 2 seconds and dials the next number.
Call or silence	LN waits for a pre-set time (answering timeout), then hangs up and dials the next number.
Continuous tone (on a PBX, e.g.)	LN hangs up in approx. 2 seconds and dials the next number.
Ringing tone - terminates before 10 rings are completed (can be reprogrammed)	Regarded as a successful call. The call goes on for the maximum pre-set time (maximum call duration). The voice message is played back once.
Ringing tone with 10 rings (can be reprogrammed)	LN hangs up and dials the next number in the sequence.
1 to 9 , 0	These digits are interpreted as the beginning of a switch control password.

Warning

- Make sure in this mode that no VoiceMail box, FAX machine or any other equipment are assigned to the numbers to be dialled that might answer the call before the pre-programmed timeout end and thus terminate automatic dialling

Automatic Call Receiving

If equipped with a PC with the 2N[®] LiftManager application, the dispatching centre receives calls automatically. It identifies the calling lifts and types of calls (alarm, checking, and automatic failure report). The checking calls are served fully automatically. The alarm calls are transferred to the operator, who uses the above mentioned commands in this case too.

Survey of Messages

English	Meaning
Attention, the call is ending.	Call end warning
We apologise; your call has to be terminated.	Call interrupted by a higher-priority request
Wait please.	During connection establishing
This is communicator number.....	Identification (if pre-programmed), The option to play back user-recorded messages (including, e.g. the lift address) is under preparation.
Checking call	Identification of a checking call
Rescue has been done.	Confirmation of emergency signalling end
More audio units are waiting for connection.	Announcement of an emergency status in (an)other lift(s)

Call End (Outgoing / Incoming Calls)

A call is terminated (line hang-up occurs) if any of the following cases happens:

- The busy or continuous tone has been detected*) (call end on PBXs).
- Timeout for call confirmation expired (see parameter 913 setting)
- The pre-programmed maximum call duration has elapsed – the "Attention, the call is ending" message is played back 10 seconds before the call end, the call can be prolonged using **4** .
- The character **5** or **#** has been received.
- The timeout expired during programming.
- A higher-priority call request.

*)The communicator is able to detect the continuous, busy and ringing tones even if the tone has two frequency components, which is the case of Great Britain, USA (so-called BTT tone) and Canada. To set the dual tone characteristics, set parameters 946 and 947.

Use of Switches

Every machine room audio unit is equipped with a switch, which enables to block the lift function in case LN fails to call for help in the event of:

- telephone line failure;
- power outage and back-up battery discharge.

The switch is provided with a normally closed (NC) contact and executes the required function automatically.

Warning

- The lift CU has to ensure that the lift always goes to the nearest station and opens the door when the contact opens

5. Maintenance

This section described the 2N[®] LiftNet product maintenance procedures.

Here is what you can find in this section:

- **5.1 Battery Maintenance**
- **5.2 Firmware Upgrade**

5.1 Battery Maintenance

First put the accumulators in operation as described in the Description and Installation section (PSTN Central Unit, Before You Start). Also, pay attention to them whenever the operation is interrupted and during replacement. The basic rules are as follows:

Warning

- Never leave the batteries discharged for unnecessarily long periods.
- If the battery is fully discharged, please recharge it as soon as possible.

Interruption of Operation

The interruption of service means that LN is without a power supply for a rather long time. The battery is not being charged and can be damaged. This situation may occur in the following cases:

- In a building under construction or in an unused building where the power supply may be turned off for weeks or even months;
- While replacing the CU;
- At the end of a testing, exhibition or similar event.

In such cases, open the CU and remove the battery or disconnect it placing the transport tape between the battery contact and the holder contact.

List of Battery Endangering Situations

1. **CU installation in an unfinished new building.** Remember that the power may be switched off for weeks or even months in a building that has not been put in operation yet. If necessary, install the communicator here, check its function and remember to protect the batteries against depletion - remove them or disconnect using the transport tape. U nového typu HW stačí přepnout vypínač do polohy OFF. If the risk is not so high, just disconnect the green connector. Both the steps, however, may only be performed when the elevators are out of operation.
2. **Excessively long storage periods.** Make sure that your storage obeys the FIFO (first in first out) principle. If the end of the six-month storage period is approaching, you may recharge the batteries in the product (see above), replace

the transport tape and continue storing the product. On new HW model, you have to switch the battery button into the position ON for charging. When are batteries full charged, then switch the battery button again into the position OFF.

3. **Dismantling CU.** If, for whatever reason (warranty claim, transport to service site in order to upgrade, etc.), you dismantle the **CU**, remember that the **CU** is still "working". This way it may be stored without recharging for no longer than 1 week, or, after having been fully recharged, no longer than 1 month. If there is a risk of exceeding this period, remove the batteries or disconnect them using the transport tape. With new HW model just switch the battery button into the position OFF before transportation.
4. **Testing, exhibitions and presentations.** If you operate the communicator for example at an exhibition, remember that the entire set may be disconnected from the power supply. In such case the batteries will discharge. Do not forget to recharge them as soon as possible, or – preferably – disconnect the green connector if you do not need to have the system on. With new HW model just switch the battery button into the position OFF before transportation.

Battery Pack Replacement

Battery Pack Service Life

- The warranty period does not apply to common wear and tear, i.e. the battery depreciation. If, however, the product is used normally, the battery service life is substantially higher than the warranty period.
- LN monitors the battery pack status and indicates the need of replacement upon a certain capacity drop.
- Where the dispatching office is equipped with the **2N[®] LiftManager** software, this information is automatically transmitted as an error message.

For replacement, four new Ni-MH accumulators of size AA and minimum capacity of 2000 mAh are needed. Make sure that accumulators of the same type and production series are used. You are recommended to use the batteries delivered in groups of four by the manufacturer. The recommended type is SANYO Eneloop 2000.

How to Replace a Battery

Instructions

1. Disconnect all supply cables from the CU.
2. Release the 6 screws on the CU bottom and remove the cover.
3. Replace the batteries and check polarity (the spring holder contact = minus pole of the cell, i.e. its flat end).
4. Replace the cover and tighten the screws into position.
5. Dispose of used battery packs in accordance with the applicable waste law. You can return them to the manufacturer too.

5.2 Firmware Upgrade

Use the Service Tool to upgrade 2N[®] LiftNet. The Service Tool upgrades the CU and all audio units connected.

Procedure

1. Connect the CU to the PC USB.
2. Start the Service Tool.



3. Click on  to connect the device, select the device from the list of connected devices and press OK.



4. Select  in the toolbar.
5. Select the FW version.
6. Select the voice menu language version.
7. Select whether to retain configuration, or reset the parameters to factory values.
8. Launch the upgrading process.
9. When the CU upgrade has been completed, you are invited to upgrade the audio units (using the Service Tool, or upgrade is executed automatically upon the system start if parameter 998 set to 1).
10. Set date and time (Device -> Date and time setting)

Caution

- Remember to set date and time after the upgrade.
- Make sure that the CU and audio units have the same FW versions to avoid system errors.
- You are recommended to factory reset the parameters to set new ranges and default values in the new FW version.

 **Tip**

- Back up your configuration, execute upgrade and factory default reset and upload the configuration into the device (new ranges and default values will be used in the new FW version).

6. Technical Parameters

Telephone Parameters

Parameter	Value	Conditions
Minimum line current	15 mA	off-hook
Minimum line voltage	22 V	on-hook
Off-hook DC voltage drop	$< 8 \text{ V} < 16 \text{ V}$	I = 25 mA I = 50 mA
Off-hook resistance	$> 1 \text{ M}\Omega$	U = 25..100 V
Off-hook impedance	$220 \Omega + 820 \Omega \text{ paral. } 115 \text{ nF}$	20 to 60 mA
Return loss	$> 14 \text{ dB}$	20 to 60 mA
Bandwidth	300 to 3500 Hz	20 to 60 mA
Ringing impedance	$> 2 \text{ k}\Omega C = 1 \mu\text{F}$	25 to 50 Hz
Ringing detector sensitivity	10 to 20 V	25 to 50 Hz
Pulse dialling	40 / 60 ms	
DTMF dialling level	$6 \text{ a } 8 \text{ dB} \pm 2 \text{ dB}$	20 to 60 mA
Dial-tone detector sensitivity	approx. 43 dB	
Overvoltage protection- between A, B	1000 V	8 / 20 μs

i Notes

- All the product parameters comply with TBR-21 on condition that the product is to be operated as a single line terminal, i.e. no parallel connection with any other equipment is allowed.
- Line interference and noise picked up by the LN microphone are relevant factors.

Other Parameters

Unit type

- **913600E** , Central unit – PSTN: 130×175×46 mm
- **913610E**, Audio unit – lift cabin, universal: 65×130×20 mm
- **913611E**, Audio unit – machine room: 225×87×67 mm
- **913612E**, Audio unit – shaft: 225×87×67 mm
- **Working temperature range:** 0 ÷ 50 °C
- **Power supply:** DC 12V / 0.5A
- **Back-up operation time, idle / call:** 24 h / 2 h
- **Battery:** 4 pieces, size AA, NiMH, min 1800 mAh
- **Switch rating (913611E, Audio unit – machine room):** Up to 48V / 100 mA

The manufacturer reserves the right to modify the product in order to improve its qualities.

The product contains no environmentally harmful components. When the product's service life is exhausted, dispose of it in accordance with applicable legal regulations.

7. Supplementary Information

This section provides supplementary information on the 2N[®] LiftNet product.

- 7.1 Troubleshooting
- 7.2 List of Abbreviations
- 7.3 Regulations
- 7.4 General Instructions and Cautions

7.1 Troubleshooting



For the most frequently asked questions refer to faq.2n.cz.

How to upgrade 2N[®] LiftNet?

1. Connect the central unit (CU) to a PC via USB.
2. Run 2N[®] LiftManager - Service Tools.
3. Select the connected CU.
4. Go to the *Device* menu and select *Perform device upgrade*.
5. Select the latest firmware version, your language and whether you want to *Preserve* or *Reset current configuration*.
6. Wait until the upgrade finishes. Then you can upgrade all the connected audio units as well. **NOTE:** The CU also upgrades all audio units after boot if parameter 998 is set to 1.

How to set up 2N[®] LiftNet?

There are three possibilities how to set 2N[®] LiftNet:

1. For remote programming you can use the telephone line. 2N[®] LiftNet will guide you by a voice navigation menu.
2. For local programming, use the machine room unit and the phone connected to it. 2N[®] LiftNet will guide you by a voice navigation menu.
3. For PC based programming use the USB interface and 2N[®] LiftManager - Service Tools.

How to upload user recorded voice messages?

1. Connect the central unit (CU) to a PC via USB.
2. Run 2N[®] LiftManager - Service Tools.
3. Go to the *Device* menu and select *User message upload*.

4. Use the **Browse** button to select files with the recorded messages. **NOTE:** The file format must be wav, PCM, 8 bit, mono, 8 kHz.
5. After selecting all the message files, click on the *Upload into device* button.

7.2 List of Abbreviations

- LN - 2N[®] LiftNet
- CU - Central unit of the system, typically shared by multiple lifts in a building
- Audio Unit - Voice communication unit for lift communication with the dispatching office or another system unit
- System - Central unit interconnected with a group of audio units by a bus
- Bus - A pair of conductors interconnecting the CU and all system audio units
- Incoming call - dispatching office-to-CU call
- Outgoing call - CU-to-dispatching office call
- Checking call - Automatically activated CU-to-dispatching office call
- Triphony - Internal communication between audio units, typically all audio units of one and the same lift, during repairs or rescue work
- Dispatching office - Receives emergency calls, checking calls and, if necessary, lift failure reports. Separate dispatching offices can be responsible for different types of calls and mobile telephones can be used too.
- LM, LiftManager - Supervisory software designed for small and medium-size lift supervising companies. Automatic receiving of checking calls. Comfortable programming of CU parameters.
- DISA - Automatic voice menu, which helps route incoming calls to the required audio unit or activate additional functions, e.g. remote programming
- ESS - Electronic Security System
- PBX - Private branch exchange (equipped with PSTN interface and local analogue lines)
- PSTN - Public switched telephone network. For simplification, it is assumed that the CU is connected to the PSTN although it works on the PBX line too in the same way

Europe

2N[®] LiftNet conforms to the following directives and regulations:

Directive 1999/5/EC of the European Parliament and of the Council, of 9 March 1999 - on radio equipment and telecommunications terminal equipment and the mutual recognition of their conformity

Directive 2006/95/EC of the European Parliament and of the Council of 12 December 2006 on the harmonisation of the laws of Member States relating to electrical equipment designed for use within certain voltage limits

Directive 2004/108/EC of the Council of 15 December 2004 on the harmonisation of the laws of Member States relating to electromagnetic compatibility

Commission Regulation (EC) No. 1275/2008, of 17 December 2008, implementing Directive 2005/32/EC of the European Parliament and of the Council with regard to ecodesign requirements for standby and off mode electric power consumption of electrical and electronic household and office equipment

Directive 2011/65/EU of the European Parliament and of the Council of 8 June 2011 on the restriction of the use of certain hazardous substances in electrical and electronic equipment

Regulation (EC) No. 1907/2006 of the European Parliament and of the Council of 18 December 2006 concerning the Registration, Evaluation, Authorisation and Restriction of Chemicals (REACH), establishing a European Chemicals Agency, amending Directive 1999/45/EC and repealing Council Regulation (EEC) No. 793/93 and Commission Regulation (EC) No. 1488/94 as well as Council Directive 76/769/EEC and Commission Directives 91/155/EEC, 93/67/EEC, 93/105/EC and 2000/21/EC

Directive 2012/19/EC of the European Parliament and of the Council of 4 July 2012 on waste electrical and electronic equipment.

7.4 General Instructions and Cautions

Please read this User Manual carefully before using the product. Follow all instructions and recommendations included herein.

Any use of the product that is in contradiction with the instructions provided herein may result in malfunction, damage or destruction of the product.

The manufacturer shall not be liable and responsible for any damage incurred as a result of a use of the product other than that included herein, namely undue application and disobedience of the recommendations and warnings in contradiction herewith.

Any use or connection of the product other than those included herein shall be considered undue and the manufacturer shall not be liable for any consequences arisen as a result of such misconduct.

Moreover, the manufacturer shall not be liable for any damage or destruction of the product incurred as a result of misplacement, incompetent installation and/or undue operation and use of the product in contradiction herewith.

The manufacturer assumes no responsibility for any malfunction, damage or destruction of the product caused by incompetent replacement of parts or due to the use of reproduction parts or components.

The manufacturer shall not be liable and responsible for any loss or damage incurred as a result of a natural disaster or any other unfavourable natural condition.

The manufacturer shall not be held liable for any damage of the product arising during the shipping thereof.

The manufacturer shall not make any warrant with regard to data loss or damage.

The manufacturer shall not be liable and responsible for any direct or indirect damage incurred as a result of a use of the product in contradiction herewith or a failure of the product due to a use in contradiction herewith.

All applicable legal regulations concerning the product installation and use as well as provisions of technical standards on electric installations have to be obeyed. The manufacturer shall not be liable and responsible for damage or destruction of the product or damage incurred by the consumer in case the product is used and handled contrary to the said regulations and provisions.

The consumer shall, at its own expense, obtain software protection of the product. The manufacturer shall not be held liable and responsible for any damage incurred as a result of the use of deficient or substandard security software.

The consumer shall, without delay, change the access password for the product after installation. The manufacturer shall not be held liable or responsible for any damage incurred by the consumer in connection with the use of the original password.

The manufacturer also assumes no responsibility for additional costs incurred by the consumer as a result of making calls using a line with an increased tariff.

Electric Waste and Used Battery Pack Handling



Do not place used electric devices and battery packs into municipal waste containers. An undue disposal thereof might impair the environment!

Deliver your expired electric appliances and battery packs removed from them to dedicated dumpsites or containers or give them back to the dealer or manufacturer for environmental-friendly disposal. The dealer or manufacturer shall take the product back free of charge and without requiring another purchase. Make sure that the devices to be disposed of are complete.

Do not throw battery packs into fire. Battery packs may not be taken into parts or short-circuited either.



An Axis company

2N TELEKOMUNIKACE a.s.

Modřanská 621, 143 01 Prague 4, Czech Republic

Phone: +420 261 301 500, Fax: +420 261 301 599

E-mail: sales@2n.cz

Web: www.2n.cz

v1.9